

EPA Emissions Regulations

Jet Drives manufactured by Mercury Marine in the United States are certified to the United States Environmental Protection Agency as conforming to the requirements of the regulations for the control of air pollution from new Jet Drive motors. This certification is contingent on certain adjustments being set to factory standards. For this reason, the factory procedure for servicing the product must be strictly followed and, wherever practicable, returned to the original intent of the design. Maintenance, replacement, or repair of the emission control devices and systems may be performed by any marine engine repair establishment or individual.

Engines are labeled with an Emission Control Information decal as permanent evidence of EPA certification.

WARNING

The engine exhaust from this product contains chemicals known to the state of California to cause cancer, birth defects or other reproductive harm.

Warranty Message

The product you have purchased comes with a **limited warranty** from Mercury Marine, the terms of the warranty are set forth in the **Warranty Information** section of this manual. The warranty statement contains a description of what is covered, what is not covered, the duration of coverage, how to best obtain warranty coverage, **important disclaimers and limitations of damages**, and other related information. Please review this important information.

The description and specifications contained herein were in effect at the time this manual was approved for printing.

Mercury Marine, whose policy is one of continued improvement, reserves the right to discontinue models at any time, to change specifications, designs, methods, or procedures without notice and without incurring obligation.

Mercury Marine, Fond du Lac, Wisconsin U.S.A.

Litho in U.S.A.

© 2013, Mercury Marine

Alpha, Axius, Bravo One, Bravo Two, Bravo Three, Circle M with Waves Logo, K-planes, Mariner, MerCathode, MerCruiser, Mercury, Mercury with Waves Logo, Mercury Marine, Mercury Precision Parts, Mercury Propellers, Mercury Racing, MotorGuide, OptiMax, Quicksilver, SeaCore, Skyhook, SmartCraft, Sport-Jet, Verado, VesselView, Zero Effort, Zeus, and #1 On the Water are registered trademarks of Brunswick Corporation. Mercury Product Protection is a registered service mark of Brunswick Corporation.

Mercury Premier Service

Mercury evaluates the service performance of its dealers and assigns its highest rating of "Mercury Premier" to those demonstrating an exceptional commitment to service.

Earning a Mercury Premier Service rating means a dealer:

- Achieves a high 12 month service CSI (Customer Satisfaction Index) score for warranty service.
- Possesses all necessary service tools, test equipment, manuals, and parts books.
- Employs at least one Certified or Master technician.
- Provides timely service for all Mercury Marine customers.
- Offers extended service hours and mobile service, when appropriate.
- Uses, displays, and stocks adequate inventory of genuine Mercury Precision Parts.
- Offers a clean, neat shop with well organized tools and service literature.

Declaration of Conformity - For Recreational Craft Propulsion Engines with the Requirements of Directive 94/25/EC as amended by Directive 2003/44/EC

Name of engine manufacturer: Mercury Marine

Address: W6250 Pioneer Road, P.O. Box 1939

Town: Fond du Lac, WI

Post Code: 54936-1939

Country: USA

Name of Authorized Representative: Brunswick Marine in EMEA Inc.
Address: Parc Industriel de Petit-Rechain
Town: Verviers **Post Code:** 4800 **Country:** Belgium

Name of Notified Body for exhaust emission assessment: Det Norske Veritas AS
Address: Veritasveien 1
Town: Hovik **Post Code:** 1322 **Country:** Norway **ID Number:** 0575

Conformity assessment module used for exhaust emissions: B+C B+D B+E B+F G H
Other Community Directives applied: Electromagnetic Compatibility Directive 2004/108/EC

Description of Engines and Essential Requirements

Engine Type	Fuel Type	Combustion Cycle
<input type="checkbox"/> Z or sterndrive without integral exhaust	<input type="checkbox"/> Diesel	<input checked="" type="checkbox"/> 2 stroke
<input checked="" type="checkbox"/> Inboard engine	<input checked="" type="checkbox"/> Petrol	<input type="checkbox"/> 4 stroke

Identification of Engines Covered by This Declaration of Conformity

Name of engine family	Unique engine identification number(s) or engine family code(s): starting serial number	EC Type-examination certificate or type-approval certificate number
200 HP Sport-Jet	0E433154	RCD-H-2 Rev 4

Essential requirements	Standards	Other normative document/ method	Technical file	Please specify in more detail (* = mandatory standard)
Annex 1.B—Exhaust Emissions				
B.1 engine identification	<input type="checkbox"/>	<input type="checkbox"/>	<input checked="" type="checkbox"/>	
B.2 exhaust emission requirements	<input checked="" type="checkbox"/> *	<input type="checkbox"/>	<input type="checkbox"/>	* EN ISO 8178-1:1996
B.3 durability	<input type="checkbox"/>	<input type="checkbox"/>	<input checked="" type="checkbox"/>	
B.4 owner's manual	<input checked="" type="checkbox"/>	<input type="checkbox"/>	<input type="checkbox"/>	ISO 8665: 2006
Annex 1.C—Noise Emissions	see Declaration of Conformity of the craft in which the engine(s) has (have) been installed			

This declaration of conformity is issued under the sole responsibility of the manufacturer. I declare on behalf of the engine manufacturer that the engine(s) will meet the exhaust emission requirements of Directive 94/25/EC as amended by Directive 2003/44/EC when installed in a recreational craft, in accordance with the engine manufacturer's supplied instructions and that this (these) engine(s) must not be put into service until the recreational craft into which it is (they are) to be installed has been declared in conformity with the relevant provisions of the above mentioned Directives.

Name / function:

Mark D. Schwabero, President
Mercury Marine



Date and place of issue:

September 04, 2012
Fond du Lac, Wisconsin, USA

Warranty Information

Warranty Registration United States and Canada.....	1
Transfer of Warranty United States and Canada.....	1
Transfer of Mercury Product Protection (Extended Service Coverage) Plan United States and Canada.....	2
Mercury Jet Products Limited Warranty.....	3
3 Year Limited Warranty Against Corrosion.....	7
Warranty Coverage and Exclusions.....	10
U.S. EPA Emissions Limited Warranty.....	13
Emission Control System Components.....	13

General Information

Boater's Responsibilities.....	15
Before Operating Your Mercury Jet Drive.....	15
Boat Horsepower Capacity.....	16
High-Speed and High-Performance Boat Operation.....	17
Towing the Watercraft in Water.....	17
Mercury Jet Drive Remote Control.....	17
Lanyard Stop Switch.....	18
Protecting People in the Water.....	20
Exhaust Emissions.....	21
Wave and Wake Jumping.....	24
Stopping the Boat in an Emergency.....	24
Selecting Accessories for Your Mercury Jet Drive.....	25
Safe Boating Suggestions.....	25
Recording Serial Numbers.....	28
Specifications.....	29
Component Identification.....	30

Fuel and Oil

Fuel Requirements.....	31
Fuel Additives.....	31
Avoiding Fuel Flow Restriction.....	31
Low Permeation Fuel Hose Requirement	31
Oil Recommendation.....	31
Fuel Recommendations.....	32
Filling Remote Oil Tank.....	34
Filling Engine-Mounted Oil Reservoir Tank.....	34

Features and Controls

Bilge Siphon.....	36
Warning Horn Signals.....	37
Engine Guardian System.....	38
SmartCraft Product.....	38

Operation

Pre-Starting Check List.....	39
Special Operating Instructions.....	40
Engine Break-In Procedure.....	43
Starting the Engine.....	43
Shifting.....	46
Stopping the Engine.....	46

Maintenance

Mercury Jet Drive Care.....	48
Replacement Parts for Your Power Package.....	48
EPA Emissions Regulations.....	48
Inspection and Maintenance Schedule.....	49
Clearing A Clogged Water Intake.....	51
Fuel System.....	53
Fuses	55
Corrosion Control Anodes.....	57
Battery Inspection	58
Spark Plug Inspection and Replacement.....	58
Flywheel Cover Removal and Installation.....	60
Alternator Belt Inspection.....	62
Compressor Air Intake Filter.....	63
Belt Tensioner Idler Pulley Lubrication.....	63
Flushing the Cooling System.....	64
Drive Housing Lubricant.....	66
Stator Assembly Lubricant.....	67
Bilge Siphon Inspection.....	70
Submerged Power Package.....	70

Storage

Storage Preparation.....	71
Protecting Internal Engine Components.....	72

Troubleshooting

Starter Motor Will Not Crank the Engine.....	73
Engine Will Not Start.....	73
Engine Runs Erratically.....	74
Performance Loss at Normal RPM.....	74
Performance Loss at Wide-Open Throttle.....	74
Battery Will Not Hold Charge.....	75

Owner Service Assistance

Local Repair Service.....	76
Parts and Accessories Inquiries.....	76
Service Assistance.....	76
Mercury Marine Service Offices.....	77
Ordering Literature.....	78

Maintenance Log

Maintenance Log.....	79
----------------------	----

WARRANTY INFORMATION

Warranty Registration United States and Canada

To be eligible for warranty coverage, the product must be registered with Mercury Marine.

At the time of sale, the selling dealer should complete the warranty registration and immediately submit it to Mercury Marine via MercNET, e-mail, or mail. Upon receipt of this warranty registration, Mercury Marine will record the registration.

A copy of the warranty registration should be provided to you by your selling dealer.

NOTE: Registration lists must be maintained by Mercury Marine and any dealer of Mercury Marine products sold in the United States, should a safety recall notification under the Federal Safety Act be required.

You may change your registered address at any time, including at time of warranty claim, by calling Mercury Marine or sending a letter or fax with your name, old address, new address, and engine serial number to Mercury Marine's warranty registration department. Your dealer can also process this change of information.

Mercury Marine

Attn: Warranty Registration Department

W6250 W. Pioneer Road

P.O. Box 1939

Fond du Lac, WI 54936-1939

920-929-5054

Fax +1 920 907 6663

OUTSIDE UNITED STATES AND CANADA

For products purchased outside the United States and Canada, contact the distributor in your country, or the Marine Power Service Center closest to you.

Transfer of Warranty United States and Canada

The limited warranty is transferable to a subsequent purchaser, but only for the remainder of the unused portion of the limited warranty. This will not apply to products used for commercial applications.

WARRANTY INFORMATION

To transfer the warranty to the subsequent owner, send or fax a copy of the bill of sale or purchase agreement, new owner's name, address, and engine serial number to Mercury Marine's warranty registration department. In the United States and Canada, mail to:

Mercury Marine
Attn: Warranty Registration Department
W6250 W. Pioneer Road
P.O. Box 1939
Fond du Lac, WI 54936-1939
920-929-5054
Fax +1 920 907 6663

Upon processing the transfer of warranty, Mercury Marine will record the new owner's information.

There is no charge for this service.

OUTSIDE THE UNITED STATES AND CANADA

For products purchased outside the United States and Canada, contact the distributor in your country, or the Marine Power Service Center closest to you.

Transfer of Mercury Product Protection (Extended Service Coverage) Plan United States and Canada

The remaining coverage period of the Product Protection Plan is transferable to the subsequent purchaser of the engine within thirty (30) days from the date of sale. Contracts not transferred within thirty (30) days of the subsequent purchase will no longer be valid and the product will no longer be eligible for coverage under the terms of the contract.

To transfer the plan to the subsequent owner, contact Mercury Product Protection or an authorized dealer to receive a Request for Transfer form. Submit to Mercury Product Protection a receipt/bill of sale, a completed Request of Transfer form, and a check payable to Mercury Marine in the amount of \$50.00 (per engine) to cover the transfer fee.

Plan coverage is not transferable from one product to another product or for noneligible applications.

The certified preowned engine plans are not transferable.

WARRANTY INFORMATION

For help or assistance, contact Mercury Product Protection Department at 1-888-427-5373 from 7:30 a.m. to 4:30 p.m. CST, Monday–Friday or e-mail mpp_support@mercmarine.com.

Mercury Jet Products Limited Warranty

UNITED STATES AND CANADA

Outside the United States and Canada - Check with your local distributor.

WHAT IS COVERED

Mercury Marine warrants its new Jet products to be free of defects in material and workmanship during the period described below.

DURATION OF COVERAGE

This Limited Warranty provides coverage for one (1) year from either the date the product is first sold, or the date on which the product is first put into service, whichever occurs first. The repair or replacement of parts, or the performance of service under this warranty, does not extend the life of this warranty beyond its original expiration date. Unexpired warranty coverage can be transferred from one recreational use customer to a subsequent recreational use customer upon proper reregistration of the product. Unexpired warranty coverage cannot be transferred either to or from a commercial use customer. Commercial use is defined as any work or employment related use of the product, or any use of the product which generates income, for any part of the warranty period, even if the product is only occasionally used for such purposes. Warranty coverage may be terminated for used repossessed product; or product purchased at auction, from a salvage yard, or from an insurance company.

WARRANTY INFORMATION

CONDITIONS THAT MUST BE MET IN ORDER TO OBTAIN WARRANTY COVERAGE

Warranty coverage is available only to retail customers that purchase from a dealer authorized by Mercury Marine to distribute the product in the country in which the sale occurred, and then only after the Mercury Marine specified predelivery inspection process is completed and documented. Warranty coverage becomes available upon proper registration of the product by the authorized dealer. Routine maintenance outlined in the Operation and Maintenance Manual must be timely performed in order to maintain warranty coverage. Mercury Marine reserves the right to make warranty coverage contingent upon proof of proper maintenance.

WHAT MERCURY WILL DO

Mercury's sole and exclusive obligation under this warranty is limited to, at our option, repairing a defective part, replacing such part or parts with new or Mercury Marine certified remanufactured parts, or refunding the purchase price of the Mercury product. Mercury reserves the right to improve or modify products from time to time without assuming an obligation to modify products previously manufactured.

WARRANTY INFORMATION

HOW TO OBTAIN WARRANTY COVERAGE

The customer must provide Mercury with a reasonable opportunity to repair, and reasonable access to the product for warranty service. Warranty claims shall be made by delivering the product for inspection to a Mercury dealer authorized to service the product. If purchaser cannot deliver the product to such a dealer, written notice must be given to Mercury. We will then arrange for the inspection and any covered repair.

Purchaser, in that case, shall pay for all related transportation charges and/or travel time. If the service provided is not covered by this warranty, purchaser shall pay for all related labor and material, and any other expenses associated with that service. Purchaser shall not, unless requested by Mercury, ship the product or parts of the product directly to Mercury. The warranty registration card is the only valid registration identification and must be presented to the dealer at the time warranty service is requested in order to obtain coverage.

WARRANTY INFORMATION

WHAT IS NOT COVERED

This limited warranty does not cover routine maintenance items, tune ups, adjustments, normal wear and tear, damage caused by abuse, abnormal use, use of a propeller or gear ratio that does not allow the engine to run in its recommended wide-open throttle RPM range (see the Operation and Maintenance Manual), operation of the product in a manner inconsistent with the recommended operation/duty cycle section of the Operation and Maintenance Manual, neglect, accident, submersion, improper installation (proper installation specifications and techniques are set forth in the installation instructions for the product), improper service, use of an accessory or part not manufactured or sold by us, jet pump impellers and wear rings or liners, operation with fuels, oils, or lubricants which are not suitable for use with the product (see the Operation and Maintenance Manual), alteration or removal of parts, water entering the engine through the fuel intake, air intake, or exhaust system, or damage to the product from insufficient cooling water caused by blockage of the cooling system by a foreign body, or running the engine out of water. Use of the product for racing or other competitive activity, or operating with racing modifications, at any point, even by a prior owner of the product, voids the warranty.

Expenses related to haul-out, launch, towing, storage, telephone, rental, inconvenience, slip fees, insurance coverage, loan payments, loss of time, loss of income, or any other type of incidental or consequential damages are not covered by this warranty. Also, expenses associated with the removal and/or replacement of boat partitions or material caused by boat design for access to the product are not covered by this warranty.

No individual or entity, including Mercury Marine authorized dealers, has been given authority by Mercury Marine to make any affirmation, representation, or warranty regarding the product, other than those contained in this limited warranty, and if made, shall not be enforceable against Mercury Marine.

WARRANTY INFORMATION

For additional information regarding events and circumstances covered by this warranty, and those that are not, see the Warranty Coverage section of the Operation and Maintenance Manual, incorporated by reference into this warranty.

DISCLAIMERS AND LIMITATIONS

THE IMPLIED WARRANTIES OF MERCHANTABILITY AND FITNESS FOR A PARTICULAR PURPOSE ARE EXPRESSLY DISCLAIMED. TO THE EXTENT THAT THEY CANNOT BE DISCLAIMED, THE IMPLIED WARRANTIES ARE LIMITED IN DURATION TO THE LIFE OF THE EXPRESS WARRANTY. INCIDENTAL AND CONSEQUENTIAL DAMAGES ARE EXCLUDED FROM COVERAGE UNDER THIS WARRANTY. SOME STATES/COUNTRIES DO NOT ALLOW FOR THE DISCLAIMERS, LIMITATIONS, AND EXCLUSIONS IDENTIFIED ABOVE, AS A RESULT, THEY MAY NOT APPLY TO YOU. THIS WARRANTY GIVES YOU SPECIFIC LEGAL RIGHTS, AND YOU MAY ALSO HAVE OTHER LEGAL RIGHTS WHICH VARY FROM STATE TO STATE AND COUNTRY TO COUNTRY.

3 Year Limited Warranty Against Corrosion

WHAT IS COVERED

We warrant each new Mercury, Mariner, Mercury Racing, Sport Jet, M² Jet Drive, Tracker by Mercury Marine Outboard, MerCruiser inboard or sterndrive engine (Product) rendered inoperative as a direct result of corrosion for the period of time described below.

DURATION OF COVERAGE

This limited corrosion warranty provides coverage for three (3) years from either the date the product is first sold, or the date on which the product is first put into service, whichever occurs first. The repair or replacement of parts, or the performance of service under this warranty does not extend the life of this warranty beyond its original expiration date. Unexpired warranty coverage can be transferred to subsequent (noncommercial use) purchaser upon proper re-registration of the product.

WARRANTY INFORMATION

CONDITIONS THAT MUST BE MET IN ORDER TO OBTAIN WARRANTY COVERAGE

Warranty coverage is available only to retail customers that purchase from a Dealer authorized by Mercury Marine to distribute the product in the country in which the sale occurred, and then only after the Mercury Marine specified pre-delivery inspection process is completed and documented. Warranty coverage becomes available upon proper registration of the product by the authorized dealer. Corrosion prevention devices specified in the Operation and Maintenance Manual must be in use on the boat, and routine maintenance outlined in the Operation and Maintenance Manual must be timely performed (including without limitation the replacement of sacrificial anodes, use of specified lubricants, and touch-up of nicks and scratches) in order to maintain warranty coverage. Mercury Marine reserves the right to make warranty coverage contingent upon proof of proper maintenance.

WHAT MERCURY WILL DO

Mercury's sole and exclusive obligation under this warranty is limited to, at our option, repairing a corroded part, replacing such part or parts with new or Mercury Marine certified re-manufactured parts, or refunding the purchase price of the Mercury product. Mercury reserves the right to improve or modify products from time to time without assuming an obligation to modify products previously manufactured.

WARRANTY INFORMATION

HOW TO OBTAIN WARRANTY COVERAGE

The customer must provide Mercury with a reasonable opportunity to repair, and reasonable access to the product for warranty service. Warranty claims shall be made by delivering the product for inspection to a Mercury dealer authorized to service the product. If purchaser cannot deliver the product to such a dealer, written notice must be given to Mercury. We will then arrange for the inspection and any covered repair.

Purchaser in that case shall pay for all related transportation charges and/or travel time. If the service provided is not covered by this warranty, purchaser shall pay for all related labor and material, and any other expenses associated with that service. Purchaser shall not, unless requested by Mercury, ship the product or parts of the product directly to Mercury. The warranty registration card is the only valid registration identification and must be presented to the dealer at the time warranty service is requested in order to obtain coverage.

WHAT IS NOT COVERED

This limited warranty does not cover electrical system corrosion; corrosion resulting from damage, corrosion, which causes purely cosmetic damage, abuse or improper service; corrosion to accessories, instruments, steering systems; corrosion to factory installed jet drive unit; damage due to marine growth; product sold with less than a one year limited Product warranty; replacement parts (parts purchased by customer); products used in a commercial application. Commercial use is defined as any work or employment related use of the product, or any use of the product, which generates income, for any part of the warranty period, even if the product is only occasionally used for such purposes.

WARRANTY INFORMATION

Corrosion damage caused by stray electrical currents (on-shore power connections, nearby boats, submerged metal) is not covered by this corrosion warranty and should be protected against by the use of a corrosion protection system, such as the Mercury Precision Parts or Quicksilver MerCathode system and/or Galvanic Isolator. Corrosion damage caused by improper application of copper base anti-fouling paints is also not covered by this limited warranty. If anti-fouling protection is required, Tri-Butyl-Tin-Adipate (TBTA) base anti-fouling paints are recommended on Outboard and MerCruiser boating applications. In areas where TBTA base paints are prohibited by law, copper base paints can be used on the hull and transom. Do not apply paint to the outboard or MerCruiser product. In addition, care must be taken to avoid an electrical interconnection between the warranted product and the paint. Refer to the **Operation and Maintenance Manual** for additional details.

For additional information regarding events and circumstances covered by this warranty, and those that are not, refer to the **Warranty Coverage** section of the **Operation and Maintenance Manual**, incorporated by reference into this warranty.

DISCLAIMERS AND LIMITATIONS: THE IMPLIED WARRANTIES OF MERCHANTABILITY AND FITNESS FOR A PARTICULAR PURPOSE ARE EXPRESSLY DISCLAIMED. TO THE EXTENT THAT THEY CANNOT BE DISCLAIMED, THE IMPLIED WARRANTIES ARE LIMITED IN DURATION TO THE LIFE OF THE EXPRESS WARRANTY. INCIDENTAL AND CONSEQUENTIAL DAMAGES ARE EXCLUDED FROM COVERAGE UNDER THIS WARRANTY. SOME STATES/COUNTRIES DO NOT ALLOW FOR THE DISCLAIMERS, LIMITATIONS AND EXCLUSIONS IDENTIFIED ABOVE, AS A RESULT, THEY MAY NOT APPLY TO YOU. THIS WARRANTY GIVES YOU SPECIFIC LEGAL RIGHTS, AND YOU MAY ALSO HAVE OTHER LEGAL RIGHTS, WHICH VARY FROM STATE TO STATE AND COUNTRY TO COUNTRY.

Warranty Coverage and Exclusions

The purpose of this section is to help eliminate some of the more common misunderstandings regarding warranty coverage. The following information explains some of the types of services that are not covered by warranty.

WARRANTY INFORMATION

Keep in mind that warranty covers repairs that are needed within the warranty period because of defects in material and workmanship. Installation errors, accidents, normal wear, and a variety of other causes that affect the product are not covered.

Warranty is limited to defects in material or workmanship, but only to retail customers that purchase from a dealer authorized by Mercury Marine to distribute the product in the country in which the sale occurred, and then only after the Mercury Marine specified predelivery inspection process is completed and documented.

Should you have any questions concerning warranty coverage, contact your authorized dealer. They will be pleased to answer any questions that you may have.

GENERAL EXCLUSIONS FROM WARRANTY

1. Minor adjustments and tune-ups, including checking, cleaning, or adjusting spark plugs, ignition components, carburetor settings, filters, belts, controls, and checking lubrication made in connection with normal services.
2. Damage caused by neglect, lack of maintenance, accident, abnormal operation, or improper installation or service.
3. Haul-out, launch, towing charges, removal and/or replacement of boat partitions or material because of boat design for necessary access to the product, all related transportation charges and/or travel time, etc. Reasonable access must be provided to the product for warranty service. Customer must deliver product to an authorized dealer.
4. Additional service work requested by customer other than that necessary to satisfy the warranty obligation.
5. Labor performed by other than an authorized dealer may be covered only under the following circumstances: When performed on an emergency basis (providing there are no authorized dealers in the area who can perform the work required or have no facilities to haul-out, etc., and prior factory approval has been given to have the work performed at this facility).

WARRANTY INFORMATION

6. All incidental and/or consequential damages (storage charges, telephone, or rental charges of any type, inconvenience, or loss of time or income) are the owner's responsibility.
7. Use of other than Mercury Precision or Quicksilver replacement parts when making warranty repairs.
8. Oils, lubricants, or fluids changed as a matter of normal maintenance is customer's responsibility unless loss or contamination of same is caused by product failure that would be eligible for warranty consideration.
9. Participating in or preparing for racing or other competitive activity or operating with a racing type components.
10. Engine noise does not necessarily indicate a serious engine problem. If diagnosis indicates a serious internal engine condition, which could result in a failure, condition responsible for noise should be corrected under the warranty.
11. Pump unit and/or impeller damage caused by either striking a submerged object, or rocks, stones, or foreign objects being drawn through the water intake grate is considered a marine hazard.
12. Water entering the engine through the fuel intake, air intake, exhaust system, or submersion.
13. Failure of any parts caused by lack of cooling water, which results from starting engine out of water, foreign material blocking inlet, or ingestion of sand and/or mud.
14. Use of fuels and lubricants which are not suitable for use with or on the product. Refer to the **Maintenance** section.
15. Our limited warranty does not apply to any damage to our products caused by the installation or use of parts and accessories which are not manufactured or sold by us. Failures which are not related to the use of those parts or accessories are covered under warranty if they otherwise meet the terms of the limited warranty for that product.

WARRANTY INFORMATION

U.S. EPA Emissions Limited Warranty

Consistent with the obligations created by 40 CFR Part 1045, Subpart B, Mercury Marine provides a five year or 175 hours of engine use, whichever occurs first, to the retail customer, that the engine is designed, built, and equipped so as to conform at the time of sale with applicable regulations under section 213 of the Clean Air Act, and that the engine is free from defects in materials and workmanship which cause the engine to fail to conform with applicable regulations. This emission-related warranty covers all the components listed in the **Emission Control System Components**.

Emission Control System Components

The EPA and California emission-related warranty covers all the following list of components:

COMPONENTS OF THE EMISSIONS CONTROL SYSTEM:

1. Fuel metering system
 - a. Carburetor and internal parts (and/or pressure regulator or fuel injection system)
 - b. Cold start enrichment system
 - c. Intake valves
2. Air induction system
 - a. Intake manifold
 - b. Turbocharger or supercharger systems (where applicable)
3. Ignition system
 - a. Spark plugs
 - b. Magneto or electronic ignition system
 - c. Spark advance/retard system
 - d. Ignition coil and/or control module
 - e. Ignition wires
4. Lubrication system (4-Stroke engines excluded)
 - a. Oil pump and internal parts
 - b. Oil injectors

WARRANTY INFORMATION

- c. Oil meter
- 5. Exhaust system
 - a. Exhaust manifold
 - b. Exhaust valves
- 6. Miscellaneous items used in above systems
 - a. Hoses, clamps, fittings, tubing, sealing gaskets or devices, and mounting hardware
 - b. Pulleys, belts, and idlers
 - c. Vacuum, temperature, check and time sensitive valves and switches
 - d. Electronic controls

The emission-related warranty does not cover components whose failure would not increase an engine's emissions on any regulated pollutant.

GENERAL INFORMATION

Boater's Responsibilities

The operator (driver) is responsible for the correct and safe operation of the boat and safety of its occupants and general public. It is strongly recommended that each operator (driver) read and understand this entire manual before operating the power package.

Be sure at least one additional person on board is instructed in the basics of starting and operating the Mercury Jet Drive, and boat handling in case the driver is unable to operate the boat.

Before Operating Your Mercury Jet Drive

Read this manual carefully. Safety and operating information that is practiced along with using good common sense can help prevent personal injury and product damage. If you have any questions, contact your dealer.

This manual as well as safety labels posted on the Mercury Jet Drive use safety alerts to draw your attention to special safety instructions that must be followed.

DANGER

Indicates a hazardous situation which, if not avoided, will result in death or serious injury.

WARNING

Indicates a hazardous situation which, if not avoided, could result in death or serious injury.

CAUTION

Indicates a hazardous situation which, if not avoided, could result in minor or moderate injury.

NOTICE

Indicates a situation which, if not avoided, could result in engine or major component failure.

IMPORTANT: Indicates information or instructions that are necessary for proper operation and/or maintenance.

GENERAL INFORMATION

Read this manual carefully. Learn the difference in handling characteristics between a Mercury Jet Drive boat and a propeller driven boat including:

- *Steering at low power/throttle* - unlike propeller driven boats, the Mercury Jet Drive boat tends to lose steering control as less water is drawn in and expelled. Increase power/throttle slightly to regain steering.
- *Maneuverability* - the Mercury Jet Drive is highly maneuverable at higher speeds; more so, than propeller driven boats. Use caution when turning to prevent spinouts.
- *Steering in reverse* - unlike propeller driven boats, turning the steering wheel turns the bow of the boat in the *same direction*.

If you have any questions, contact your dealer.

Safety and operating information that is practiced along with using good common sense can help prevent personal injury and product damage.

Boat Horsepower Capacity

WARNING

Exceeding the boat's maximum horsepower rating can cause serious injury or death. Overpowering the boat can affect boat control and flotation characteristics or break the transom. Do not install an engine that exceeds the boat's maximum power rating.

GENERAL INFORMATION

Do not overpower or overload your boat. Most boats will carry a required capacity plate indicating the maximum acceptable power and load as determined by the manufacturer following certain federal guidelines. If in doubt, contact your dealer or the boat manufacturer.

U.S. COAST GUARD CAPACITY	
MAXIMUM HORSEPOWER	XXX
MAXIMUM PERSON CAPACITY (POUNDS)	XXX
MAXIMUM WEIGHT CAPACITY	XXX

26777

High-Speed and High-Performance Boat Operation

If your Mercury Jet Drive is to be used in a high-speed or high-performance boat with which you are unfamiliar, we recommend that you never operate it at its high speed capability without first requesting an initial orientation and familiarization demonstration ride with your dealer or an operator experienced with your Mercury Jet Drive. For additional information, obtain a copy of our **Hi-Performance Boat Operation** booklet from your dealer, distributor, or Mercury Marine.

Towing the Watercraft in Water

If towing a stranded Mercury Jet Drive powered watercraft in water, the towing speed must be slow. Keep the towing speed at or around idle speed.

Keeping the towing speed slow will prevent water from being forced up through the exhaust system and into the engine. Water entering the engine can cause damage to internal engine parts.

Mercury Jet Drive Remote Control

The remote control connected to your Mercury Jet Drive must be equipped with a start-in-gear protection device. This prevents the engine from starting when the Mercury Jet Drive is in forward or reverse.

GENERAL INFORMATION

⚠ WARNING

Starting the engine with the drive in gear can cause serious injury or death. Never operate a boat that does not have a neutral-safety-protection device.

Lanyard Stop Switch

The purpose of a lanyard stop switch is to turn off the engine when the operator moves far enough away from the operator's position (as in accidental ejection from the operator's position) to activate the switch. A lanyard stop switch can be installed as an accessory - generally on the dashboard or side adjacent to the operator's position.

The lanyard is a cord usually 122–152 cm (4–5 feet) in length when stretched out, with an element on one end made to be inserted into the switch and a snap on the other end for attaching to the operator. The lanyard is coiled to make its at-rest condition as short as possible to minimize the likelihood of lanyard entanglement with nearby objects. Its stretched-out length is made to minimize the likelihood of accidental activation should the operator choose to move around in an area close to the normal operator's position. If it is desired to have a shorter lanyard, wrap the lanyard around the operator's wrist or leg, or tie a knot in the lanyard.

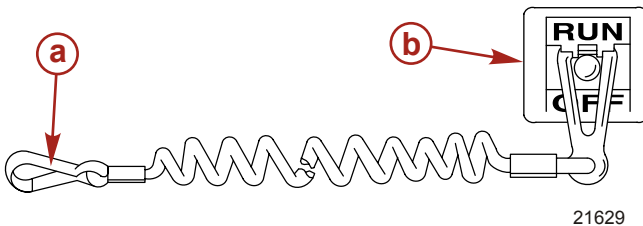

- a** - Lanyard cord
- b** - Lanyard stop switch

Read the following Safety Information before proceeding.

GENERAL INFORMATION

Important Safety Information: The purpose of a lanyard stop switch is to stop the engine when the operator moves far enough away from the operator's position to activate the switch. This would occur if the operator accidentally falls overboard or moves within the boat a sufficient distance from the operator's position. Falling overboard and accidental ejections are more likely to occur in certain types of boats such as low sided inflatables, bass boats, high performance boats, and light, sensitive handling fishing boats operated by a hand tiller. Falling overboard and accidental ejections are also likely to occur as a result of poor operating practices such as sitting on the back of the seat or gunwale at planing speeds, standing at planing speeds, sitting on elevated fishing boat decks, operating at planing speeds in shallow or obstacle infested waters, releasing your grip on a steering wheel that is pulling in one direction, drinking alcohol or consuming drugs, or daring high speed boat maneuvers.

While activation of the lanyard stop switch will stop the engine immediately, a boat will continue to coast for some distance depending upon the velocity and degree of any turn at shut down. However, the boat will not complete a full circle. While the boat is coasting, it can cause injury to anyone in the boat's path as seriously as the boat would when under power.

We strongly recommend that other occupants be instructed on proper starting and operating procedures should they be required to operate the engine in an emergency (e.g. if the operator is accidentally ejected).

WARNING

If the operator falls out of the boat, stop the engine immediately to reduce the possibility of serious injury or death from being struck by the boat. Always properly connect the operator to the stop switch using a lanyard.

GENERAL INFORMATION

⚠ WARNING

Avoid serious injury or death from deceleration forces resulting from accidental or unintended stop switch activation. The boat operator should never leave the operator's station without first disconnecting the stop switch lanyard from the operator.

Accidental or unintended activation of the switch during normal operation is also a possibility. This could cause any, or all, of the following potentially hazardous situations:

- Occupants could be thrown forward due to unexpected loss of forward motion - a particular concern for passengers in the front of the boat who could be ejected over the bow and possibly struck by the gearcase or propeller.
- Loss of power and directional control in heavy seas, strong current, or high winds.
- Loss of control when docking.

KEEP THE LANYARD STOP SWITCH AND LANYARD CORD IN GOOD OPERATING CONDITION

Before each use, check to ensure the lanyard stop switch works properly. Start the engine and stop it by pulling the lanyard cord. If the engine does not stop, have the switch repaired before operating the boat.

Before each use, visually inspect the lanyard cord to ensure it is in good working condition and that there are no breaks, cuts, or wear to the cord. Check that the clips on the ends of the cord are in good condition. Replace any damaged or worn lanyard cords.

Protecting People in the Water



GENERAL INFORMATION

WHILE YOU ARE CRUISING

It is very difficult for a person standing or floating in the water to take quick action to avoid a boat heading in their direction even at slow speed.

Always slow down and exercise extreme caution any time you are boating in an area where there might be people in the water.

Avoid shallow water or where any loose material such as sand, shells, seaweed, grass, tree branches, etc. can be sucked in and expelled from the pump as a high speed projectile.

WHILE BOAT IS STATIONARY

Stop the Mercury Jet Drive engine immediately whenever anyone in the water is near your boat. The Mercury Jet Drive is always drawing water through the water intake grate when the engine is running. Stay away from the water intake located under the stern (back) of the boat and never insert an object into the water intake or water outlet nozzle when the engine is running.

WARNING

Avoid injury resulting from contacting the rotating impeller or having hair, clothing, or loose objects drawn into the water intake and wrapping around the impeller shaft. Stay away from the water intake and never insert an object into the water intake or water outlet nozzle when the engine is running.

Exhaust Emissions

BE ALERT TO CARBON MONOXIDE POISONING

Carbon monoxide (CO) is a deadly gas that is present in the exhaust fumes of all internal combustion engines, including the engines that propel boats, and the generators that power boat accessories. By itself, CO is odorless, colorless, and tasteless, but if you can smell or taste engine exhaust, you are inhaling CO.

Early symptoms of carbon monoxide poisoning, which are similar to the symptoms of seasickness and intoxication, include headache, dizziness, drowsiness, and nausea.

GENERAL INFORMATION

WARNING

Inhaling engine exhaust gases can result in carbon monoxide poisoning, which can lead to unconsciousness, brain damage, or death. Avoid exposure to carbon monoxide.

Stay clear from exhaust areas when engine is running. Keep the boat well-ventilated while at rest or underway.

STAY CLEAR OF EXHAUST AREAS

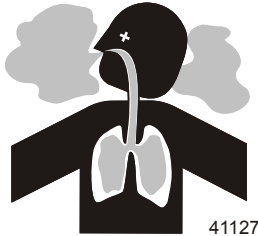

Engine exhaust gases contain harmful carbon monoxide. Avoid areas of concentrated engine exhaust gases. When engines are running, keep swimmers away from the boat, and do not sit, lie, or stand on swim platforms or boarding ladders. While underway, do not allow passengers to be positioned immediately behind the boat (platform dragging, teak/body surfing). This dangerous practice not only places a person in an area of high engine exhaust concentration, but also subjects them to the possibility of injury from the boat propeller.

GOOD VENTILATION

Ventilate the passenger area, open side curtains or forward hatches to remove fumes.

Example of desired air flow through the boat:

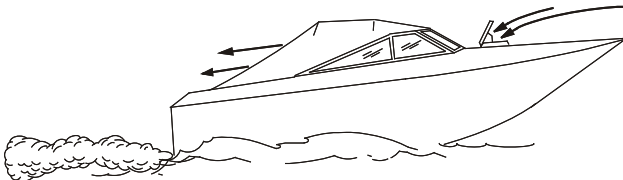

5448

GENERAL INFORMATION

POOR VENTILATION

Under certain running and/or wind conditions, permanently enclosed or canvas enclosed cabins or cockpits with insufficient ventilation may draw in carbon monoxide. Install one or more carbon monoxide detectors in your boat.

Although the occurrence is rare, on a very calm day, swimmers and passengers in an open area of a stationary boat that contains, or is near, a running engine may be exposed to a hazardous level of carbon monoxide.

1. Examples of poor ventilation while the boat is stationary:

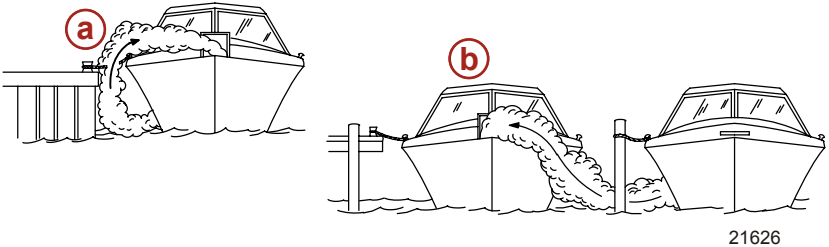

- a** - Running the engine when the boat is moored in a confined space
- b** - Mooring close to another boat that has its engine operating

2. Examples of poor ventilation while the boat is moving:

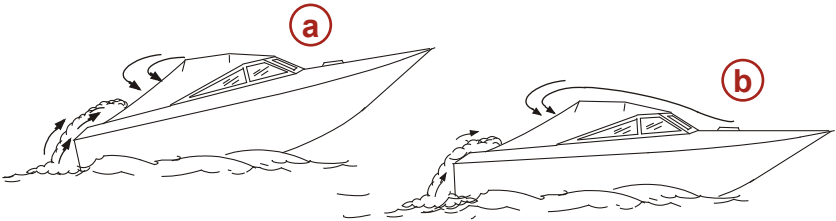

- a** - Operating the boat with the trim angle of the bow too high
- b** - Operating the boat with no forward hatches open (station wagon effect)

GENERAL INFORMATION

Wave and Wake Jumping

Operating recreational boats over waves and wake is a natural part of boating. However, when this activity is done with sufficient speed to force the boat hull partially or completely out of the water, certain hazards arise, particularly when the boat reenters the water.



5450

The primary concern is the boat changing direction while in the midst of the jump. In such case, the landing may cause the boat to veer violently in a new direction. Such a sharp change in direction can cause occupants to be thrown out of their seats, or out of the boat.

WARNING

Wave or wake jumping can cause serious injury or death from occupants being thrown within or out of the boat. Avoid wave or wake jumping whenever possible.

There is another less common hazardous result from allowing your boat to launch off a wave or wake. If the bow of your boat pitches down far enough while airborne, upon water contact it may penetrate under the water surface and submarine for an instant. This will bring the boat to a nearly instantaneous stop and can send the occupants flying forward. The boat may also steer sharply to one side.

Stopping the Boat in an Emergency

Your jet-powered boat has emergency stopping capability unique to this form of propulsion.

GENERAL INFORMATION

In an emergency, shift the Jet Drive into reverse and apply throttle to rapidly slow down the boat and reduce the stopping distance. Keep in mind, however, that such a maneuver may cause occupants in the boat to be thrown forward or even out of the boat.

WARNING

Using the emergency stopping capability of a jet drive unit will slow down the boat in an emergency. However, sudden stopping may cause the occupants of the boat to be thrown forward or out of the boat resulting in serious injury or death. Use caution when performing the emergency stopping procedure, and be sure to practice in a safe area.

Emergency stopping may cause the bow to submerge and take on a large quantity of water if too much power is applied in reverse. This procedure should be practiced in a safe area, gradually increase throttle in reverse until bow is just above the waterline.

Selecting Accessories for Your Mercury Jet Drive

Genuine Mercury Precision or Quicksilver Accessories have been specifically designed and tested for your Mercury Jet Drive. These accessories are available from Mercury Marine dealers.

IMPORTANT: Check with your dealer before installing accessories. The misuse of approved accessories or the use of nonapproved accessories can damage the product.

Some accessories not manufactured or sold by Mercury Marine are not designed to be safely used with your Mercury Jet Drive operating system. Acquire and read the installation, operation and maintenance manuals for all your selected accessories.

Safe Boating Suggestions

In order to safely enjoy the waterways, familiarize yourself with local and other governmental boating regulations and restrictions, and consider the following suggestions.

GENERAL INFORMATION

Use flotation devices. Have an approved personal flotation device of suitable size for each person aboard (it is the law) and have it readily accessible.

Do not overload your boat. Most boats are rated and certified for maximum load (weight) capacities (refer to your boat capacity plate). If in doubt, contact your dealer or the boat's manufacturer.

Perform safety checks and required maintenance. Follow a regular schedule and ensure that all repairs are properly made.

Know and obey all nautical rules and laws of the waterways.

Boat operators should complete a boating safety course.

Courses are offered in the U.S.A. by 1) the U.S. Coast Guard Auxiliary, 2) the Power Squadron, 3) the Red Cross, and 4) your state boating law enforcement agency. Inquiries may be made to the Boating Hotline, 1-800-368-5647 or the Boat U.S. Foundation information number 1-800-336-BOAT.

Make sure everyone in the boat is properly seated. Do not allow anyone to sit or ride on any part of the boat that was not intended for such use. This includes the back of seats, gunwales, transom, bow, decks, raised fishing seats, any rotating fishing seat; or anywhere that an unexpected acceleration, sudden stopping, unexpected loss of boat control, or sudden boat movement could cause a person to be thrown overboard or into the boat.

Never be under the influence of alcohol or drugs while boating (it is the law). Alcohol or drug use impairs your judgment and greatly reduces your ability to react quickly.

Prepare other boat operators. Instruct at least one other person onboard in the basics of starting and operating your Mercury Jet Drive, and boat handling, in case the driver becomes disabled or falls overboard.

Passenger boarding. Stop the engine whenever passengers are boarding, unloading, or are near the back (stern) of the boat. Just shifting the outboard into neutral is not sufficient.

GENERAL INFORMATION

Be alert. The operator of the boat is responsible by law to maintain a proper lookout by sight and hearing. The operator must have an unobstructed view particularly to the front. No passengers, load, or fishing seats should block the operator's view when operating the boat above idle speed.

Never drive your boat directly behind a water-skier in case the skier falls. As an example, your boat traveling at 40 km/h (25 MPH) will overtake a fallen skier 61 m (200 ft) in front of you in 5 seconds.

Watch fallen skiers. When using your boat for waterskiing or similar activities, always keep a fallen or down skier on the operator's side of the boat while returning to assist the skier. The operator should always have the down skier in sight and never back up to the skier or anyone in the water.

Report accidents. Boat operators are required by law to file a Boating Accident Report with their state boating law enforcement agency when their boat is involved in certain boating accidents. A boating accident must be reported if 1) there is loss of life or probable loss of life, 2) there is personal injury requiring medical treatment beyond first aid, 3) there is damage to boats or other property where the damage value exceeds \$500.00, or 4) there is complete loss of the boat. Seek further assistance from local law enforcement.

Avoid shallow water conditions. Avoid operating your Mercury Jet Drive in very shallow water or where there is a noticeable amount of floating debris or weeds. Always be in at least 3 feet of water, especially when accelerating from idle speeds. Any loose material such as sand, shells, stones, seaweed, grass, etc. can be drawn up by the pump and may cause any of the following problems:

1. Engine overheat
2. Steering loss
3. Objects expelled from the pump at high speeds
4. Pump damage

GENERAL INFORMATION

Recording Serial Numbers

ENGINE AND JET PUMP

It is important to record these numbers for future reference. The jet pump and engine serial numbers are different and unique. For convenience, a decal listing both the powerhead and pump serial number is located on the engine.

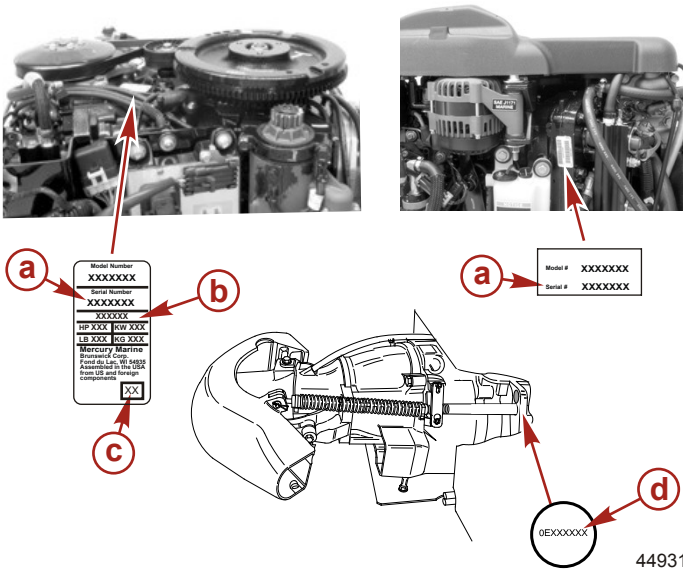

- a** - Engine serial number
- b** - Model designation
- c** - Year of manufacture
- d** - Pump serial number

GENERAL INFORMATION

Specifications

Description	Specifications
Model	200
Horsepower	200
Kilowatts	149.1
Full throttle RPM range	5150–5650
Idle speed RPM range	900–1000
Number of cylinders	6
Piston displacement	2508 cc (153 in ³)
Cylinder bore	88.4 mm (3.500 in.)
Stroke	67.3 mm (2.650 in.)
Spark plug	NGK IZFR6J-11 or NGK IZFR6J
Spark plug gap	1.1 mm (0.043 in.)
Recommended gasoline	Refer to Fuel and Oil
Recommended oil	Refer to Fuel and Oil
Battery rating (minimum)	1000 marine cranking amps (MCA) or 800 cold cranking amps (CCA)
Charging system output	60 A
Emission control system	Electronic engine control (EC)

GENERAL INFORMATION

Component Identification

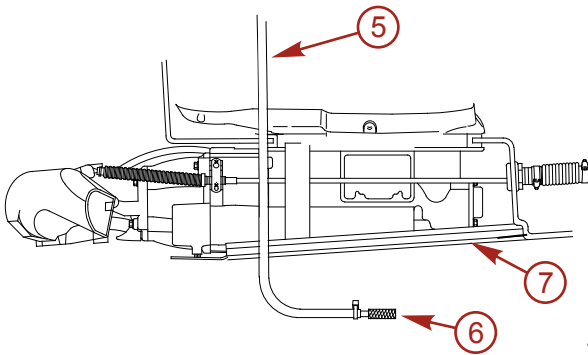
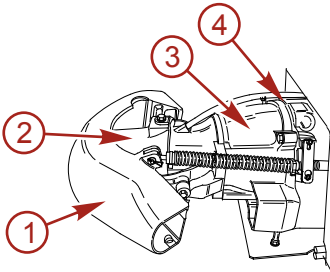

44935

- 1 - Reverse gate
- 2 - Rudder
- 3 - Stator
- 4 - Wear ring
- 5 - Bilge siphon hose - from engine
- 6 - Bilge siphon pickup screen
- 7 - Water intake

FUEL AND OIL

Fuel Requirements

Do not use premixed gas and oil in this engine. The engine automatically receives extra oil during engine break-in. Use a fresh supply of the recommended gasoline during engine break-in and after engine break-in.

Fuel Additives

To minimize carbon deposit buildup in the engine, it is recommended to add Mercury or Quicksilver Quikleen Engine Treatment additive to the engine's fuel at each tank fill throughout the boating season. Use additive as directed on container.

Avoiding Fuel Flow Restriction

IMPORTANT: Adding components to the fuel supply system (filters, valves, fittings, etc.) may restrict the fuel flow. This may cause engine stalling at low speed, and/or a lean fuel condition at high RPM that could cause engine damage.

Low Permeation Fuel Hose Requirement

Required for outboards manufactured for sale, sold, or offered for sale in the United States.

- The Environmental Protection Agency (EPA) requires that any outboard manufactured after January 1, 2009, must use low permeation fuel hose for the primary fuel hose connecting the fuel tank to the outboard.
- Low permeation hose is USCG Type B1-15 or Type A1-15, defined as not exceeding $15/\text{gm}^2/24 \text{ h}$ with CE 10 fuel at $23 \text{ }^\circ\text{C}$ as specified in SAE J 1527 - marine fuel hose.

Oil Recommendation

Recommended Oil	OptiMax Oil or Premium Plus 2-Cycle TCW 3 Outboard Oil
-----------------	--

FUEL AND OIL

Mercury OptiMax/DFI or Quicksilver DFI 2-Cycle Engine Oil is recommended for your engine. If Mercury OptiMax/DFI or Quicksilver DFI 2-Cycle Engine Oil is not available, we recommend using Mercury or Quicksilver TC-W3 Premium Plus 2-Cycle Oil. Severe engine damage may result from use of an inferior oil.

Fuel Recommendations

IMPORTANT: Use of improper gasoline can damage your engine. Engine damage resulting from the use of improper gasoline is considered misuse of the engine, and damage caused thereby will not be covered under the limited warranty.

FUEL RATINGS

Mercury Marine engines will operate satisfactorily when using a major brand of unleaded gasoline meeting the following specifications:

USA and Canada - having a posted pump octane rating of 87 (R+M)/2 minimum. Premium gasoline (92 [R+M]/2 octane) is also acceptable. Do not use leaded gasoline.

Outside USA and Canada - having a posted pump octane rating of 90 RON minimum. Premium gasoline (98 RON) is also acceptable. If unleaded gasoline is not available, use a major brand of leaded gasoline.

USING REFORMULATED (OXYGENATED) GASOLINES (USA ONLY)

This type of gasoline is required in certain areas of the USA. The two types of oxygenates used in these fuels are alcohol (ethanol) or ether (MTBE or ETBE). If ethanol is the oxygenate that is used in the gasoline in your area, refer to **Gasolines Containing Alcohol**.

These reformulated gasolines are acceptable for use in your Mercury Marine engine.

FUEL AND OIL

GASOLINES CONTAINING ALCOHOL

If the gasoline in your area contains either methanol (methyl alcohol) or ethanol (ethyl alcohol), you should be aware of certain adverse effects that can occur. These adverse effects are more severe with methanol. Increasing the percentage of alcohol in the fuel can also worsen these adverse effects.

Some of these adverse effects are caused because the alcohol in the gasoline can absorb moisture from the air, resulting in a separation of the water/alcohol from the gasoline in the fuel tank.

The fuel system components on your Mercury Marine engine will withstand up to 10% alcohol content in the gasoline. We do not know what percentage your boat's fuel system will withstand. Contact your boat manufacturer for specific recommendations on the boat's fuel system components (fuel tanks, fuel lines, and fittings). Be aware that gasolines containing alcohol may cause increased:

- Corrosion of metal parts
- Deterioration of rubber or plastic parts
- Fuel permeation through rubber fuel lines
- Starting and operating difficulties

WARNING

Fuel leakage is a fire or explosion hazard, which can cause serious injury or death. Periodically inspect all fuel system components for leaks, softening, hardening, swelling, or corrosion, particularly after storage. Any sign of leakage or deterioration requires replacement before further engine operation.

Because of possible adverse effects of alcohol in gasoline, it is recommended that only alcohol-free gasoline be used where possible. If only fuel containing alcohol is available, or if the presence of alcohol is unknown, increased inspection frequency for leaks and abnormalities is required.

FUEL AND OIL

IMPORTANT: When operating a Mercury Marine engine on gasoline containing alcohol, storage of gasoline in the fuel tank for long periods should be avoided. Long periods of storage, common to boats, create unique problems. In cars, alcohol-blend fuels normally are consumed before they can absorb enough moisture to cause trouble, but boats often sit idle long enough for phase separation to take place. In addition, internal corrosion may take place during storage if alcohol has washed protective oil films from internal components.

Filling Remote Oil Tank

Remove filler cap and fill with the specified oil. Oil tank capacity is 11.5 liters (3 gallons). Replace filler cap and tighten securely.

IMPORTANT: Always make sure the oil tank caps are threaded on tight. An air leak will prevent oil flow to the engine.

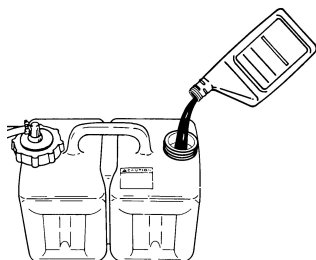

2723

Filling Engine-Mounted Oil Reservoir Tank

NOTE: Filling this tank is only necessary if the oil level should ever drop and the low oil warning system is activated.

1. Loosen the fill cap on the engine oil reservoir tank. Run the engine until all the air has been vented out of the oil reservoir tank and the tank is filled with oil to the point of overflow.

FUEL AND OIL

2. Retighten the fill cap.

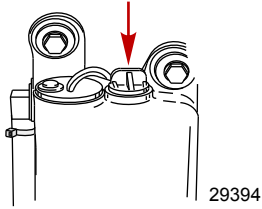

FEATURES AND CONTROLS

Bilge Siphon

The Mercury Jet Drive incorporates an automatic bilge siphoning feature. The bilge siphon is working whenever the engine is running above idle speeds. Maximum performance of the bilge siphon is realized above 3000 RPM.

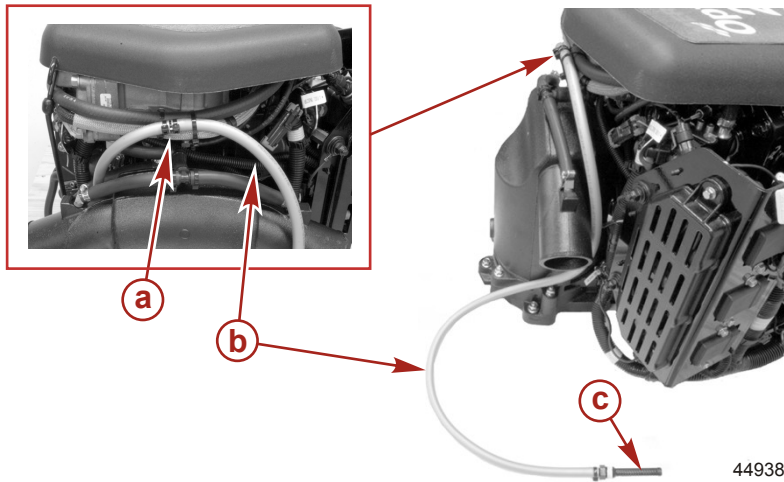

- a** - Siphon break
- b** - Bilge siphon hose
- c** - Bilge water pickup screen

Water exiting the jet pump nozzle creates a suction or vacuum in the hose attached to the nozzle. The hose is routed to and positioned in the bilge on the side of the jet tunnel.

The bilge siphon system incorporates a siphon break, which prevents water from siphoning back into the boat when the engine is turned off. This siphon break must be located at the highest point of the hose routing and must be above the waterline.

The siphon break requires periodic inspection to ensure proper operation. The air hole must remain open and free from obstruction – 508 mm (0.020 in.).

FEATURES AND CONTROLS

Warning Horn Signals

When the key switch is turned to the "ON" position, the horn will turn on for a moment as a test to show the horn is working.

The warning horn will emit either a continuous beep or intermittent short beeps. This will alert the operator and help identify the following listed situations (see chart below). For visual display of the specific engine functions and for additional engine data, refer to **SmartCraft Product** information, following.

Warning Horn		
Function	Sound	Description
Start up	One beep	Normal system test
Low oil reserve	Four beeps every two minutes	Oil level is low in the engine-mounted oil reservoir. Refill the engine-mounted oil reservoir along with the remote oil tank. Refer to Fuel and Oil .
Water in fuel	Four beeps every two minutes	Water in the water separating fuel filter reaches the full level. Water can be removed from the filter. Refer to Maintenance - Fuel System for filter removal.
Cooling system problem	Continuous	Engine Guardian System is activated. Power limit will vary with level of overheat. Stop engine and check water intake for obstruction.
Oil level is critically low	Continuous	Engine Guardian System is activated. Power limit will allow a fast idle. The oil level is critically low in the engine-mounted oil reservoir. Refill the engine-mounted oil reservoir along with the remote oil tank. Refer to Fuel and Oil .
Oil pump failure	Continuous	Engine Guardian System is activated. Power limit will allow a fast idle. The warning horn is activated if the oil pump should ever stop functioning electrically. No lubricating oil is being supplied to the engine.
Sensor out of range	Continuous	Engine Guardian System is activated. Power limit may restrict engine speed to idle.
	Intermittent beep	

FEATURES AND CONTROLS

Engine Guardian System

The Engine Guardian System monitors the critical sensors on the engine for any early indications of problems. The system will respond to a problem by emitting a continuous beep and/or reducing engine power in order to provide engine protection.

If Guardian System has been activated, reduce throttle speed. The horn will turn off when throttle speed is within the allowable limit. Consult your dealer for assistance.

SmartCraft Product

A Mercury SmartCraft System instrument package can be purchased for this Mercury Jet Drive. A few functions the instrument package will display are engine RPM, coolant temperature, battery voltage, fuel consumption, and engine operating hours.

The SmartCraft instrument package will also aid in Engine Guardian diagnostics. The SmartCraft instrument package will display critical engine alarm data and potential problems.

NOTE: If equipped with SmartCraft instruments, the Check Engine icon will be displayed during the engine break-in period.

OPERATION

Pre-Starting Check List

- Operator knows safe navigation, boating, and operating procedures.
- An approved personal flotation device of suitable size for each person aboard and readily accessible (it is the law).
- Know your boat's maximum load capacity. Look at the boat capacity plate.
- Check fuel supply.
- Check oil level in oil reservoir.
- Make sure the boat drain plug is installed.
- Tell someone where you are going and when you expect to return.
- It is illegal to operate a boat while under the influence of alcohol or drugs.
- Know the waters you will be using; tides, currents, sand bars, rock, and other hazards.
- Make inspection checks listed in the **Inspection and Maintenance Schedule**. Refer to **Maintenance** section.
- Operate the bilge blower for at least five minutes to remove any explosive fumes from the engine compartment. If boat is not equipped with a bilge blower, open engine hatch and leave open while starting engine.
- Before launching, examine the jet drive pump inlet for obstructions which may prevent pumping of water.
- Check steering for free operation.
- Check for debris around the rudder and reverse gate which may jam or hinder operation.

OPERATION

Special Operating Instructions

OPERATING ON THE WATER

WARNING

A loss or reduction in water jet thrust will directly affect boat directional control, and may result in property damage, personal injury, or death. Boat directional control can also be substantially reduced or lost altogether by a sudden loss of power such as running out of gas, quickly backing off the throttle, turning off the ignition switch, activating the lanyard stop switch, or plugging the water intake to the jet pump. Use caution when maneuvering at high speeds in areas where debris (weeds, logs, gravel, etc.) could be picked up into the jet drive. The ability to take evasive action is dependent on sufficient water jet thrust to control the boat.

A jet drive boat has substantially different handling characteristics compared to a propeller driven boat. It is suggested that you adjust yourself to these characteristics by experimentation in open water at both high and low speeds.

Although jet drive applications do not pose some of the risks associated with exposed propeller driven systems, the following steps must always be kept in mind.

1. The jet drive works by drawing water up through the bottom water intake and redirects it to the rear for forward thrust. The Mercury Jet Drive has a steerable rudder that can direct the jet thrust to the right or left. If the engine stops or the water flow is blocked, this will stop the jet thrust causing the boat to slow to a stop. However, while slowing there will be no ability to steer as steering is dependent on jet thrust.
2. Avoid the use of neutral or reverse when skiing to minimize the chance that the ski rope will be drawn up into the jet pump intake. Turn the engine off when waiting for skiers. Ensure the ski rope is clear before starting the engine.
3. Avoid weed areas or traverse weed areas at high speeds. If unavoidable, keep the boat on plane until cleared of weeded area.

OPERATION

4. Avoid operating the jet drive in very shallow water or where there is a noticeable amount of floating debris or weeds, especially when accelerating from idle. Any loose material such as sand, shells, stones, seaweed, grass, etc. can be drawn up by the pump and cause the following problems:
 - Engine overheat
 - Steering loss
 - Blockage
 - Loss of forward or reverse motion
 - Damage to the impeller, wear ring, or stator
 - Objects expelled from the pump at high speeds
5. When beaching the boat, idle in forward to reach the beach. Turn the engine off without shifting to neutral. When leaving, push the boat into approximately three feet of deep water. Start engine and shift to forward, avoid the use of neutral and reverse in shallow water.
6. If the jet intake becomes fouled such that the boat cannot reach planing speeds, it may be possible to clear the obstruction as follows (perform this maneuver only in an area clear of obstacles and hazards as steering control will momentarily be lost):
 - a. Run the boat forward at maximum attainable nonplaning speed and turn left.
 - b. Turn the engine off while in forward. Turning the engine off while in forward allows water to flush backward through the jet and across the intake. As the boat coasts to a stop, water may flush away the obstruction.
7. When the jet drive is in neutral, the drive impeller continues to rotate. However, the reverse gate is positioned so that some of the forward thrust is diverted to create reverse thrust. This approximate balancing of forward and reverse thrust will minimize any boat movement. However, because the impeller is always rotating and creating thrust when the engine is running, the boat may tend to creep slowly forward or backward. This is normal for a direct-drive, jet-driven boat. The operator should be aware of this and use caution whenever the engine is running.

OPERATION

8. The jet drive is always drawing water into the housing when the engine is running. DO NOT operate the jet drive with the grate removed from the water intake. Keep your hands, feet, hair, loose clothing, life jackets, etc. away from the water intake in the bottom of the boat. Never insert an object into the water intake or water outlet nozzle when the engine is running.

WARNING

Avoid injury resulting from contacting the rotating impeller or having hair, clothing, or loose objects drawn into the water intake and wrapping around the impeller shaft. Stay away from the water intake and never insert an object into the water intake or water outlet nozzle when the engine is running.

OPERATING IN FREEZING TEMPERATURES

If there is a chance of ice forming on the water, remove the boat from the water. If ice should form at the water level inside the jet drive, it will block water flow to the engine, causing possible damage.

OPERATING IN SALTWATER OR POLLUTED WATER

We recommend that you flush the internal water passages of your engine with fresh water after each time you operate in salt or polluted water. This will prevent a buildup of deposits from clogging the water passages. Refer to the flushing procedure in the **Maintenance** section.

Remove the boat and jet drive from the water when not in use.

Wash down the exterior and interior of the jet drive with fresh water after each use. Each month, spray Quicksilver or Mercury Precision Corrosion Guard on external metal surfaces. Do not spray Corrosion Guard on the corrosion control anodes. Coating the anodes with Corrosion Guard will reduce the effectiveness of the anodes.

OPERATION

Engine Break-In Procedure

NOTE: Do not use premixed gas and oil in this engine. Use straight gasoline during engine break-in and after engine break-in.

The engine break-in procedure for your OptiMax engine is important to ensure proper performance and maximum life from the engine. The following break-in procedure allows the internal engine parts to wear-in evenly. Incorrect engine break-in can shorten the engine life.

The engine automatically receives extra oil during the first hours of operation. For most boaters, this extra oil mode will be complete in about ten hours.

First hour

- Allow engine to warm-up for 30–60 seconds.
- Avoid continuous operation at idle speed for more than 10 minutes.
- Run the engine the majority of time between 3000–4500 RPM, approximately three quarter throttle.
- Vary engine speed; change engine speed approximately every two minutes.
- Short bursts of full throttle for periods up to 10 seconds are acceptable.

Next three hours

- Change engine speed every 10 minutes.

Starting the Engine

Before starting, read the **Pre-Starting Check List**, **Special Operating Instructions**, and **Engine Break-In Procedure**.

WARNING

Explosive fumes contained in the engine compartment can cause serious injury or death from fire or explosion. Before starting the engine, operate the bilge blower or vent the engine compartment for at least five minutes.

OPERATION

1. Before starting, operate the bilge blower for at least five minutes to remove explosive fumes from the engine compartment.

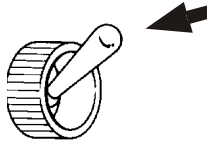

4640

⚠ CAUTION

Never start or run the jet drive without water circulating through the cooling system to prevent damage to the unit.

2. Do not start the jet drive unless water is supplied to the engine. Make sure the water intake is submerged. If using the flushing attachment, ensure that water is flowing through the engine at its maximum flow before starting. When using the flushing attachment do not operate the engine above idle speeds.



5461

OPERATION

3. Ensure that the lanyard stop switch is properly connected to both the operator and the switch. Place the switch in the "RUN" position.

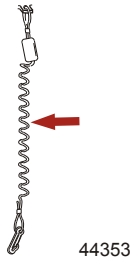

4. Shift the jet drive into neutral. Do not advance the throttle speed past idle for starting.

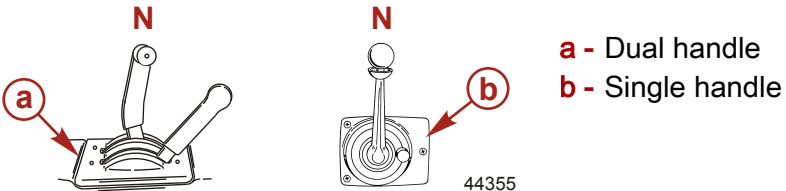

5. For initial start of a new engine or for an engine that ran out of fuel or was drained of fuel, fill the fuel system as follows:
 - a. Turn the ignition key switch to the "ON" position for three seconds and then back to the "OFF" position for five seconds.
 - b. Continue this procedure five times to allow the electric fuel pump to fill the fuel system.
6. Turn ignition key to the "START" position. If engine fails to start in ten seconds, return key to the "ON" position, wait 30 seconds, and try again.

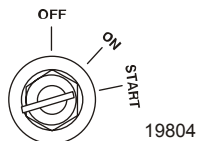

NOTE: The electronic starting system will automatically prime (choke) the engine and increase idle speed for starting.

OPERATION

Shifting

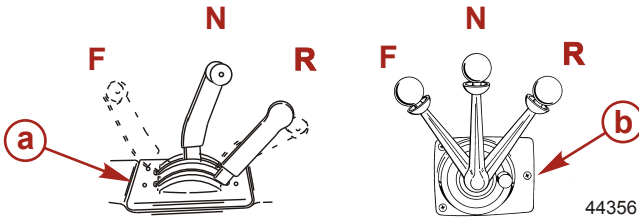

- a** - Dual handle
- b** - Single handle

1. The Mercury jet drive has three shift positions to provide operation: Forward (F), Neutral (N), Reverse (R).
 - a. Forward (F) - has all the water clearing the reverse gate for forward thrust and forward boat motion.
 - b. Neutral (N) - has the reverse gate covering half the water outlet nozzle to distribute thrust both forward and backward. The drive impeller continues to rotate and the boat may tend to creep in one direction. This is normal for a direct-drive jet-driven boat. Use caution whenever the engine is running.
 - c. Reverse (R) - has the reverse gate covering the entire water outlet nozzle to divert the exiting water stream forward to reverse boat motion.
2. After shifting into forward or reverse, advance the throttle lever further to increase speed.

NOTE: Operators must practice the stopping maneuver to become familiar with jet-drive handling.

3. To stop the boat normally, gradually reduce speed before shifting to neutral position. Use caution when shifting and turning since some loss of steering control will result. Remember, steering control is dependent on thrust produced.

Stopping the Engine

1. Reduce engine speed until the boat comes to a complete stop.

OPERATION

2. Shift the jet drive into neutral.
3. Turn the ignition key to the "OFF" position.

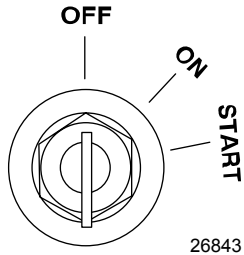

MAINTENANCE

Mercury Jet Drive Care

WARNING

Neglect or improper maintenance, repairs, or inspections of the power package can result in product damage or serious injury or death. Perform all procedures as described in this manual. If you are not familiar with proper maintenance or service procedures, consign the work to an authorized Mercury Marine dealer.

To ensure safety and retain dependability, keep your power package in the best operating condition by performing the periodic inspections and maintenance listed in the **Inspection and Maintenance Schedule**. Record maintenance performed in the **Maintenance Log** at the back of this book. Save all maintenance work orders and receipts.

Replacement Parts for Your Power Package

Mercury recommends using original Mercury Precision replacement parts and lubricants.

EPA Emissions Regulations

All new Mercury Jet Drives manufactured by Mercury Marine are certified to the United States Environmental Protection Agency, as conforming to the requirements of the regulations for the control of air pollution from new Mercury Jet Drive motors. This certification is contingent on certain adjustments set to factory standards. For this reason, the factory procedure for servicing the product must be strictly followed and, wherever practicable, returned to the original intent of the design. **Maintenance, replacement, or repair of the emission control devices and systems may be performed by any marine spark ignition (SI) engine repair establishment or individual.**

MAINTENANCE

EMISSION CERTIFICATION LABEL

An emission certification label, showing emission levels and engine specifications directly related to emissions, is placed on the engine at the time of manufacture.

MERCURY		EMISSION CONTROL INFORMATION	
THIS ENGINE CONFORMS TO <input type="checkbox"/> CALIFORNIA AND U.S. EPA EMISSION REGULATIONS FOR SPARK IGNITION MARINE ENGINES			
REFER TO OWNERS MANUAL FOR REQUIRED MAINTENANCE, SPECIFICATIONS, AND ADJUSTMENTS			
IDLE SPEED (in gear): <input type="text"/>		FAMILY: <input type="text"/>	
<input type="text"/> hp	<input type="text"/> L	HC+NOx:FEL: <input type="text"/> g/kWh	
<input type="text"/> kw		CO FEL: <input type="text"/> g/kWh	
<input type="text"/>		SPARK PLUG: <input type="text"/>	
<input type="text"/>		GAP: <input type="text"/>	
LOW PERM/HIGH PERM: <input type="text"/>			

43210

- a** - Idle speed
- b** - Engine horsepower
- c** - Piston displacement
- d** - Engine power - kilowatts
- e** - Date of manufacture
- f** - Family number
- g** - Regulated emission limit for the engine family
- h** - Regulated emission limit for the engine family
- i** - Recommended spark plug and gap
- j** - Percent of fuel line permeation

OWNER RESPONSIBILITY

The owner/operator is required to have routine engine maintenance performed to maintain emission levels within prescribed certification standards.

The owner/operator is not to modify the engine in any manner that would alter the horsepower or allow emission levels to exceed their predetermined factory specifications.

Inspection and Maintenance Schedule

PRIOR TO EVERY USE

- Check that lanyard stop switch stops the engine.
- Visually inspect the fuel system for deterioration or leaks.

MAINTENANCE

- Check the engine compartment and use your nose to detect any fuel fumes.
- Check the throttle, shift, and steering system for binding or loose components.

AFTER EACH SALTWATER OR POLLUTED WATER USE

- Flush all internal passages with fresh water.
- Wash the jet pump exterior with fresh water.

EVERY 10 HOURS OR ONCE A MONTH, WHICHEVER OCCURS FIRST

- Check bilge siphon system. See **Bilge Siphon Inspection**.
- Inspect cable bellows for wear, rub marks, or leaks.
- Inspect battery and connections. See **Spark Plug Inspection and Replacement**.
- Check tightness of bolts, nuts, and other fasteners.
- Check exhaust hoses for holes or distortion due to overheating.

EVERY 50 HOURS OR ONCE A MONTH, WHICHEVER OCCURS FIRST

- Check level and condition of drive housing and stator lubricant. See **Drive Housing Lubricant**.
- Check the corrosion control anodes. Replace if over 50% corroded. See **Corrosion Control Anodes**.
- Check tightness of bolts, nuts, and other fasteners.

EVERY 100 HOURS OR ONCE YEARLY, WHICHEVER OCCURS FIRST

- Replace spark plugs at first 100 hours or first year. After that, inspect spark plugs every 100 hours or once yearly. Replace spark plugs as needed. See **Spark Plug Inspection and Replacement**.
- Drain and replace drive housing lubricant. See **Drive Housing Lubricant**.
- Drain and replace stator housing lubricant. See **Stator Assembly Lubricant**.

MAINTENANCE

- Remove impeller and lubricate impeller shaft with Quicksilver or Mercury Precision 2-4-C w/PTFE to prevent impeller from seizing to the shaft.
- Inspect alternator belt. See **Alternator Belt Inspection**.
- Lubricate the belt tensioned pivot shaft. See **Belt Tensioner Idler Pulley Lubrication**.
- Replace engine fuel line filter. See **Fuel System**.
- Replace water separating fuel filter. See **Fuel System**.
- Replace compressor air intake filter. See **Compressor Air Intake Filter**.

BEFORE PERIODS OF STORAGE

- Refer to the **Storage** section.

Clearing A Clogged Water Intake

The hydro-surge (weed) grate and casted aluminum grate are intended for general use. The rock grate is intended for use if operating the jet drive in rocky, shallow conditions.

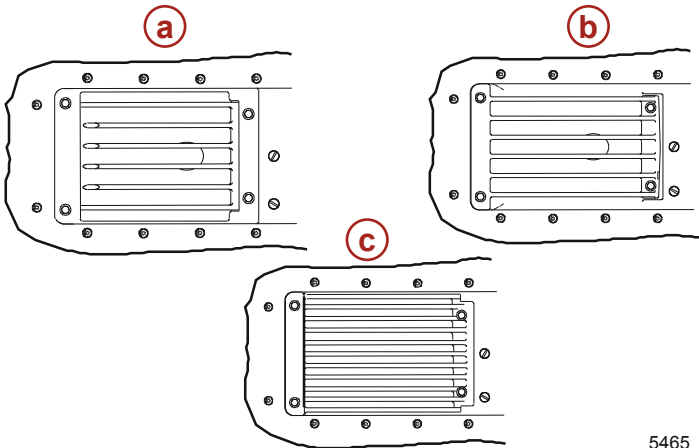

5465

- a** - Hydro-surge grate
- b** - Casted aluminum grate
- c** - Rock grate

MAINTENANCE

MANUAL CLEARING

WARNING

Avoid injury resulting from contacting the rotating impeller or having hair, clothing, or loose objects drawn into the water intake and wrapping around the impeller shaft. Stay away from the water intake and never insert an object into the water intake or water outlet nozzle when the engine is running.

If weeds or debris clog the water intake, turn the engine off and completely clean out the blockage to return the unit to proper running order.

1. Turn off the engine and remove the key from the ignition switch. The pump impeller still spins and pumps water when the engine is running, even when in neutral.
2. Clean debris from the entire jet drive unit (water intake, impeller, and nozzle). If the jet drive cannot be easily cleaned, return the boat to the trailer or to a boat lift before performing any further work.
3. It may be necessary to remove the water intake grate from the bottom of the jet drive to clean debris from the water intake. Remove the water intake grate by removing the four screws. Reinstall the water intake grate with the same four screws. Apply Loctite 242 to the threads of the screws. Tighten the screws to the specified torque.

Tube Ref No.	Description	Where Used	Part No.
 66	Loctite 242 Threadlocker	Water intake grate screws	92-809821

Description	Nm	lb-in.	lb-ft
Front screws	23	200	
Rear screws	8.5	75	

IMPORTANT: Do not operate the jet drive without the water intake grate installed.

MAINTENANCE

HYDRO-SURGE GRATE

The hydro-surge grate is spring-loaded. If the intake gets plugged, the pump suction will pull open the grate, and the water will push the blockage pass the grate and clear the intake.

If operating the boat at slow speeds in weedy areas, the water intake grate can become plugged with weeds. A plugged grate causes the pump to cavitate during acceleration (over-revving without thrusting the boat).

If the grate becomes plugged:

1. Slowly advance the throttle to get the boat up on plane, making sure not to cavitate the pump.
2. Continue to advance the throttle until the boat is running at top speed. The force of the water should clear the pump of any remaining weeds.

Fuel System

WARNING

Fuel is flammable and explosive. Ensure that the key switch is off and the lanyard is positioned so that the engine cannot start. Do not smoke or allow sources of spark or open flame in the area while servicing. Keep the work area well ventilated and avoid prolonged exposure to vapors. Always check for leaks before attempting to start the engine, and wipe up any spilled fuel immediately.

Before servicing any part of the fuel system, stop the engine and disconnect the battery. Drain the fuel system completely. Use an approved container to collect and store fuel. Wipe up any spillage immediately. Material used to contain spillage must be disposed of in an approved receptacle. Any fuel system service must be performed in a well-ventilated area. Inspect any completed service work for signs of fuel leakage.

FUEL LINE INSPECTION

Visually inspect the fuel line for cracks, swelling, leaks, hardness, or other signs of deterioration or damage. If any of these conditions are found, the fuel line must be replaced.

MAINTENANCE

FUEL LINE FILTER

Replace the fuel filter once a season or every 100 hours of use.

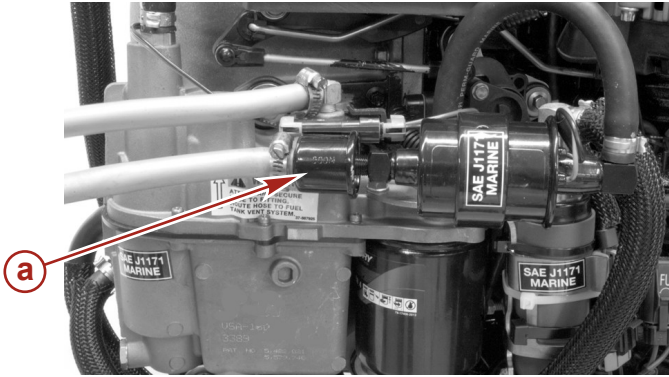

a - Fuel filter

IMPORTANT: Visually inspect for fuel leakage from the filter connections.

WATER SEPARATING FUEL FILTER

This filter removes moisture and debris from the fuel. If the filter becomes filled with water, the water can be removed. If the filter becomes plugged with debris, replace the filter. The warning system engages when water in the fuel filter reaches the full level. Refer to **Warning System** in **Features and Controls**.

Refer to the **Inspection and Maintenance Schedule** for the proper maintenance interval.

Remove and replace filter as follows:

1. Turn ignition key switch to the "OFF" position.

MAINTENANCE

2. Disconnect the wire from the bottom of the filter. Remove the filter (a) by turning the filter in the direction of the arrow (clockwise). Tip the filter to drain the fluid into a suitable container.

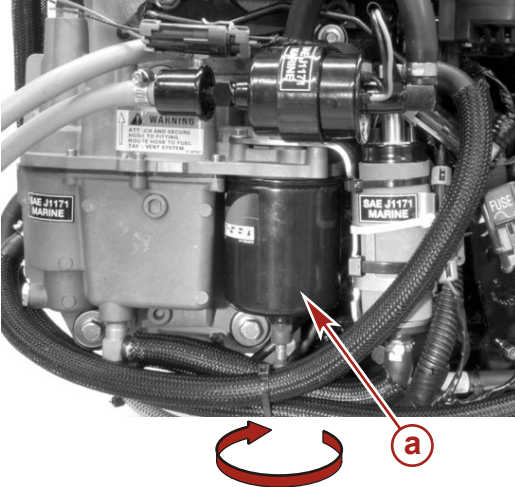

44939

a - Water separating fuel filter

3. Lubricate the sealing ring on the filter with oil. Thread on the filter and tighten securely by hand. Reconnect the wire to the filter.

Fuses

IMPORTANT: Always carry spare 5 and 20 amp fuses.

The electrical wiring circuits on the engine are protected from overload by fuses in the wiring. If a fuse is open, try to locate and correct the cause of the overload. If the cause is not found, the fuse may open again.

1. Open the fuse holder and look at the silver colored band inside the fuse. If the band is broken, replace the fuse.
2. Replace the fuse with a new fuse with the same rating.

MAINTENANCE

The fuses and circuits are identified as follows:

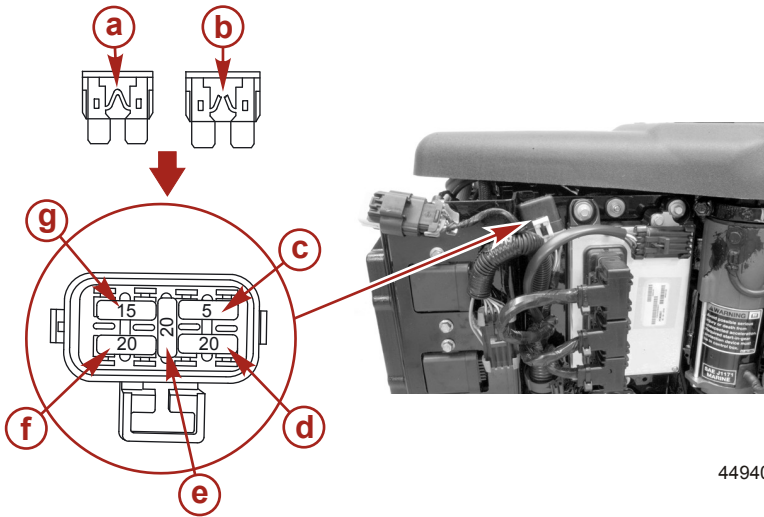

44940

- a** - Good fuse
- b** - Blown fuse
- c** - SmartCraft data bus circuit - 5 amp fuse
- d** - Ignition system circuit - 20 amp fuse
- e** - Spare fuse
- f** - Electric fuel pump (VST)/ECM driver power/oil pump circuit - 20 amp fuse
- g** - Main power relay - 15 amp fuse

MAINTENANCE

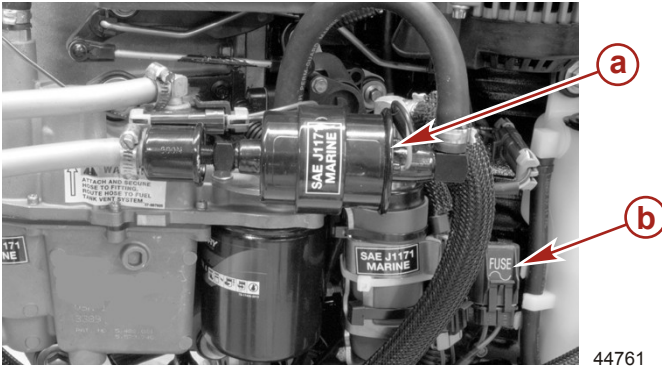

- a** - Lift pump
- b** - Lift pump circuit - 5 amp fuse

Corrosion Control Anodes

NOTICE

Anodes made of insufficiently pure aluminum alloys may not adequately protect critical drive components from corrosion. We recommend using anodes sold through Mercury Precision Parts only.

Anodes help protect the power package against galvanic corrosion by sacrificing its metal to be slowly eroded instead of other metals.

This model has three corrosion control anodes: One on the bottom of the nozzle, one on the reverse gate, and one under the rudder. Anodes help protect the Mercury Jet Drive against galvanic corrosion by sacrificing its metal to be slowly eroded instead of the Mercury Jet Drive metals.

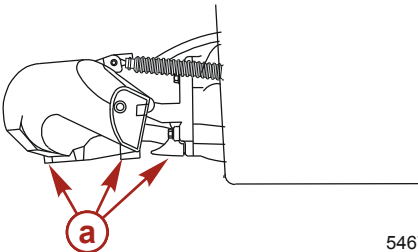

a - Anodes

5467

MAINTENANCE

All anodes require periodic inspection, especially in saltwater. Inspect anodes periodically (refer to the **Inspection and Maintenance Schedule**). Replace any anodes before they are 50% corroded. Never paint or apply protective coating on the anode, as effectiveness of the anode will be reduced.

Battery Inspection

The battery should be inspected at periodic intervals to ensure proper engine starting capability.

IMPORTANT: Read the safety and maintenance instructions which accompany your battery.

1. Turn off the engine before servicing the battery.
2. Ensure the battery is secure against movement.
3. Battery cable terminals should be clean, tight, and correctly installed. Positive to positive and negative to negative.
4. Ensure the battery is equipped with a nonconductive shield to prevent accidental shorting of battery terminals.

Spark Plug Inspection and Replacement

WARNING

Damaged spark plug boots may emit sparks that can ignite fuel vapors under the engine cowl, resulting in serious injury or death from a fire or explosion. To avoid damaging the spark plug boots, do not use any sharp object or metal tool to remove the spark plug boots.

1. Loosen the hoses from the expansion chamber. Remove the six nuts that secures the expansion chamber. Remove the expansion chamber.

MAINTENANCE

2. Open J-clips to move fuel/air lines out of the way.

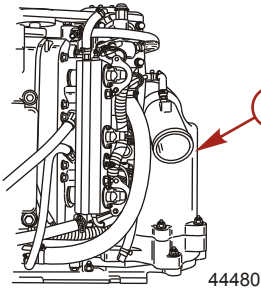

a - Expansion chamber

3. Remove the spark plug boots by twisting the rubber boots slightly and pull off.

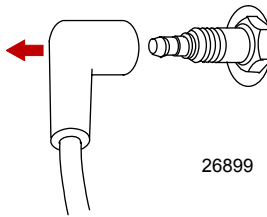

4. Remove the spark plugs to inspect. Replace the spark plug if the electrode is worn or the insulator is rough, cracked, broken, blistered, or fouled.

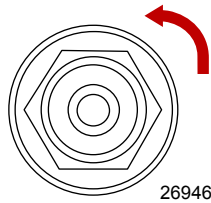

5. Set the spark plug gap to specifications.

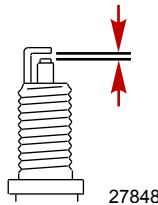

Spark Plug Gap	1.1 mm (0.043 in.)
----------------	--------------------

MAINTENANCE

- Before installing spark plugs, clean off any dirt on the spark plug seats. Install plugs finger-tight, and then tighten 1/4 turn or tighten to the specified torque.

Description	Nm	lb-in.	lb-ft
Spark plug	27		20

- Inspect the expansion chamber gasket on the adapter plate. Do not remove the gasket from the adapter plate. Replace if damaged.
- Install the expansion chamber. Tighten the mounting nuts to the specified torque. Install the hoses to the expansion chamber and secure with clamps.
- Inspect the exhaust system for leaks.

Description	Nm	lb-in.	lb-ft
Expansion chamber mounting nuts	27		20

Flywheel Cover Removal and Installation

REMOVAL

- Detach the retaining strap.
- Remove the cover by lifting off from the back of the engine.

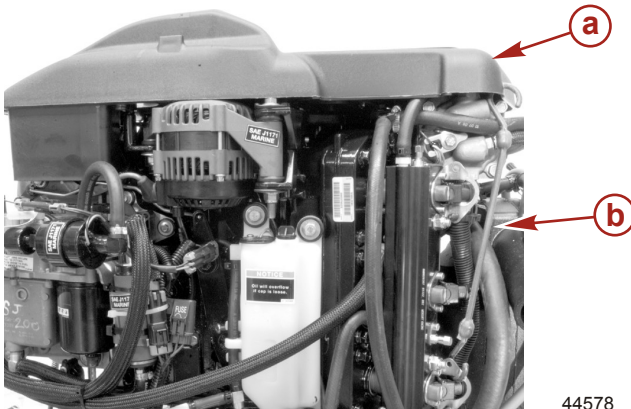

- a** - Flywheel cover
- b** - Retaining strap

MAINTENANCE

INSTALLATION

1. Lower the cover opening onto the air plenum intake flange. Tilt the cover side to side until the cover slides down onto the intake flange.
2. Push the cover down onto the alignment pins and onto the air intake tube for the air compressor.

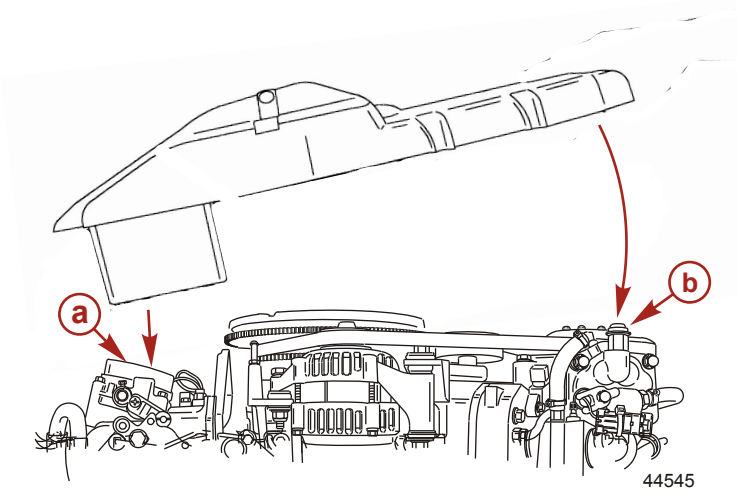

a - Air plenum intake flange

b - Air intake tube for the air compressor

MAINTENANCE

3. Attach the retaining strap to the cover.

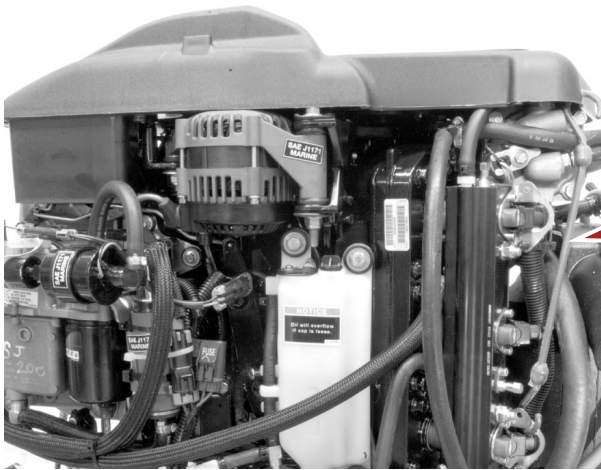

44528

a - Retaining strap

Alternator Belt Inspection

Inspect the alternator belt and have it replaced by an authorized dealer if any of the following conditions are found:

- Cracks or deterioration in the rubber portion of the belt.
- Belt surfaces rough or uneven.
- Signs of wear on edges or outer surfaces of belt.

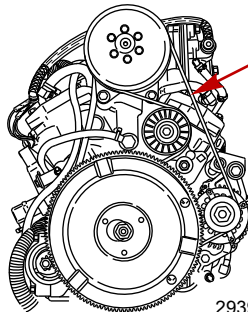

29398

MAINTENANCE

Compressor Air Intake Filter

The filter should be changed every 100 hours of operation, or once a season.

IMPORTANT: Never run the engine without the air filter.

REMOVAL

1. Remove the flywheel cover from the engine.
2. Snap out the retainer and remove the filter.

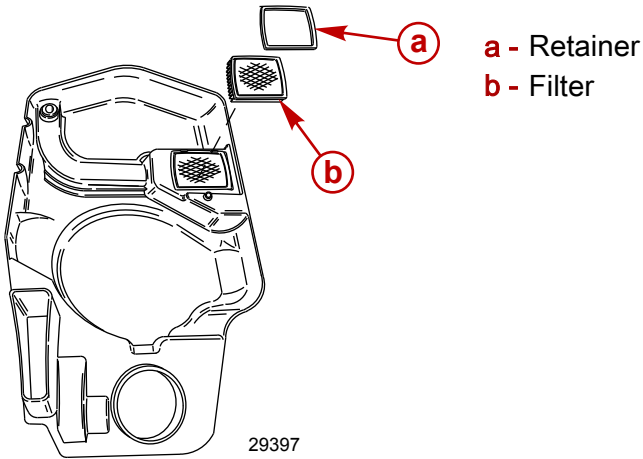

INSTALLATION

1. Install the filter into the cover.
2. Secure the filter into cover with the retainer.

Belt Tensioner Idler Pulley Lubrication

Lubricate through the fitting with 2-4-C with PTFE.

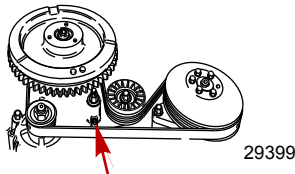

MAINTENANCE

Tube Ref No.	Description	Where Used	Part No.
 95	2-4-C with PTFE	Tensioner pulley grease fitting	92-802859A 1

Flushing the Cooling System

Flushing the cooling system is essential after each use in saltwater, after the boat has run aground, or when the overheat warning horn sounds.

CAUTION

Never start or run the jet drive without water circulating through the cooling system to prevent damage to the unit.

NOTICE

Flushing the cooling system with the bow down will result in water ingestion, which will damage the engine. When flushing the cooling system, the boat must be level or bow-up (maximum of 20 degrees). Engine damage caused by improper flushing of the cooling system is not covered by warranty.

1. Ensure that the engine is off.
2. Position the boat so that it is level or the bow is up by no more than 20°. Flushing the engine with the boat in any position outside of this range can damage the engine and void your warranty.
3. Remove the cap from the boat's flush adapter. The adapter may be mounted to the hull or in the engine compartment.

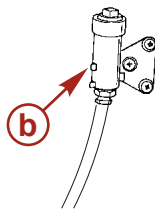
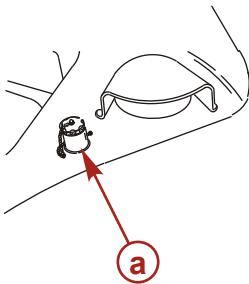

- a** - Flushing attachment (hull mount)
- b** - Flushing attachment (engine compartment mount)

5469

IMPORTANT: Do not run the engine above idle when flushing.

MAINTENANCE

4. Turn the water on full. Start the engine and let it run for at least 10 minutes to flush the engine block.

NOTE: *An insufficient flow of water to the engine may cause the engine to overheat. If the warning horn sounds, stop the engine immediately and allow the engine to cool.*

5. Stop the engine, turn off the water, and remove the water hose from the flush adapter. Install the cap and tighten it securely.
6. Flush the outer surfaces of the water outlet nozzle with water.

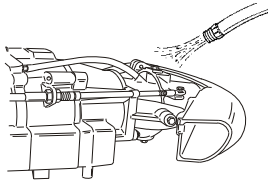

5470

MAINTENANCE

Drive Housing Lubricant

DRAINING LUBRICANT

NOTE: When draining the drive housing lubricant, visually check for water in the lubricant. It may have settled to the bottom and will drain before the lubricant or it may have mixed with the lubricant, giving it a milky color. In either case, have the drive housing checked by your authorized Mercury Marine dealer. Water in the lubricant can cause premature gear or bearing failure or, in freezing weather, damage to the drive housing.

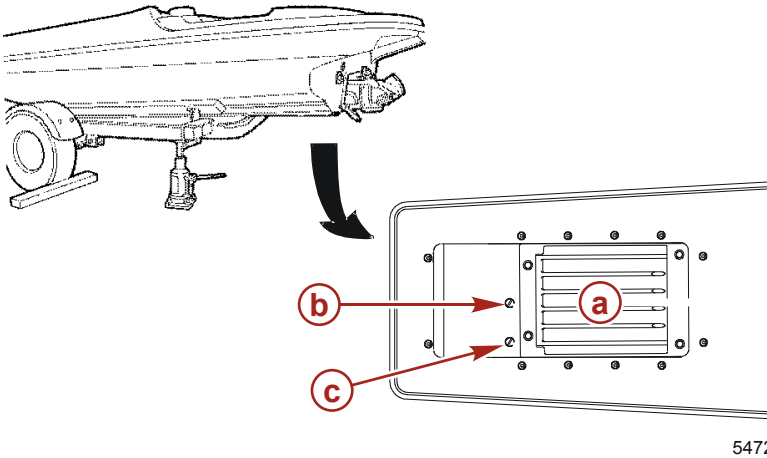

5472

- a** - Drive housing (bottom view)
- b** - Fill/drain screw
- c** - Vent screw

1. Place a drain pan below the drive.
2. Remove the fill/drain screw.
3. Remove the vent screw to drain the lubricant.

ADDING LUBRICANT

Fluid Type	Capacity
High Performance Gear Lube	725 cc (24 oz)

1. Insert the nozzle of the gear lubricant tube in the drive housing's fill/drain hole.

MAINTENANCE

2. Add lubricant to the point of overflow.
3. Install the vent screw. Ensure that the screw gasket is in place.
4. Remove the nozzle of the tube and install the fill/drain screw with the gasket.

Stator Assembly Lubricant

DRAINING LUBRICANT

NOTE: When draining stator lubricant, visually check for water in the lubricant. It may have settled to the bottom and will drain before the lubricant, or it may have mixed with the lubricant giving it a milky color. In either case, have the stator checked by your authorized Mercury Marine dealer. Water in the lubricant can cause premature bearing failure or, in freezing weather, damage to the stator.

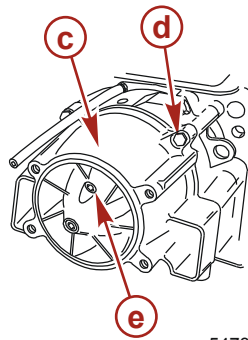
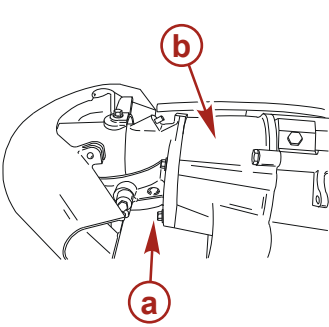

5473

- a** - Screws securing nozzle assembly (4)
- b** - Nozzle assembly
- c** - Stator assembly
- d** - Screws securing stator assembly (4)
- e** - Fill hole and plug

1. Disconnect the shift and steering cables from the reverse gate and rudder. Be careful not to change adjustments.
2. Remove the four screws securing the nozzle assembly to the stator.
3. Remove the nozzle.

MAINTENANCE

4. Remove the four screws securing the stator assembly to the drive housing and the two screws to the ride plate.
5. Remove the stator.
6. Remove the plug from the fill hole at the rear of the stator.
7. Tip the stator forward to drain the lubricant initially.
8. Tip the stator to drain the remaining lubricant out the fill hole.

ADDING OR REFILLING LUBRICANT

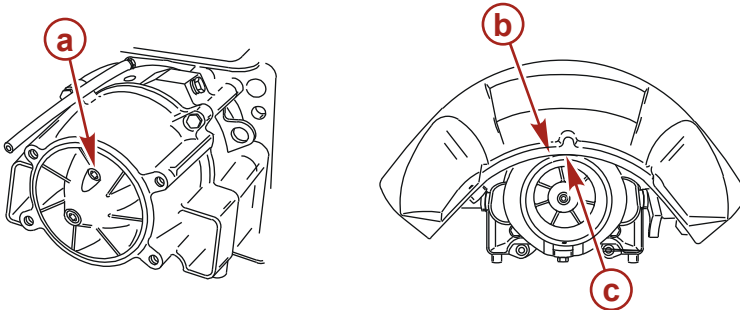

5474

- a** - Fill hole
- b** - Reverse gate (bottom edge)
- c** - Rudder (outside diameter)

Fluid Type	Capacity
High Performance Gear Lube	562 ml (19 fl oz)

1. Install the stator to the pump. Be careful when sliding the shaft past the seals to prevent damage to the seals. Apply Loctite 242 to the four stator bolts and the two ride plate screws. Tighten the screws to the specified torque.

Tube Ref No.	Description	Where Used	Part No.
 66	Loctite 242 Threadlocker	Stator bolts and ride plate screws	92-809821

MAINTENANCE

Description	Nm	lb-in.	lb-ft
Stator bolts	47		35
Ride plate screws	8.5	75	

2. Insert the nozzle of the lubricant tube in the fill hole on the stator.
3. Add lubricant until it appears at the hole.
4. Install the plug.
5. Apply Loctite 271 to four nozzle screws. Install the nozzle assembly and anode. Secure with four screws. Tighten the screws to the specified torque.

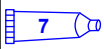
Tube Ref No.	Description	Where Used	Part No.
 7	Loctite 271 Threadlocker	Nozzle screws	92-809819

Description	Nm	lb-in.	lb-ft
Nozzle screws	47		35

6. Connect the steering and shift cables.
7. Shift and steer the unit through the entire range and check for any binding or stiffness. Correct adjustments as necessary.
8. Shift to forward position and check that the reverse gate is not preloaded. You should be able to slightly rock the reverse gate up and down. Excessive play requires shift cable adjustment.
9. Check that the bottom edge of the reverse gate is above the outside diameter of the rudder. If the reverse gate is below the outer diameter of the rudder, do not operate the boat. See an authorized Mercury Marine dealer for proper adjustment.

IMPORTANT: Adjust the shift cable so that the reverse gate does not interfere with water flow coming out of the rudder. If the reverse gate is hanging in the water flow, a strong vibration may be felt in the control box and failure of the forward stop or other components will result.

MAINTENANCE

Bilge Siphon Inspection

Inspect the bilge siphon system at periodic intervals to ensure maximum performance.

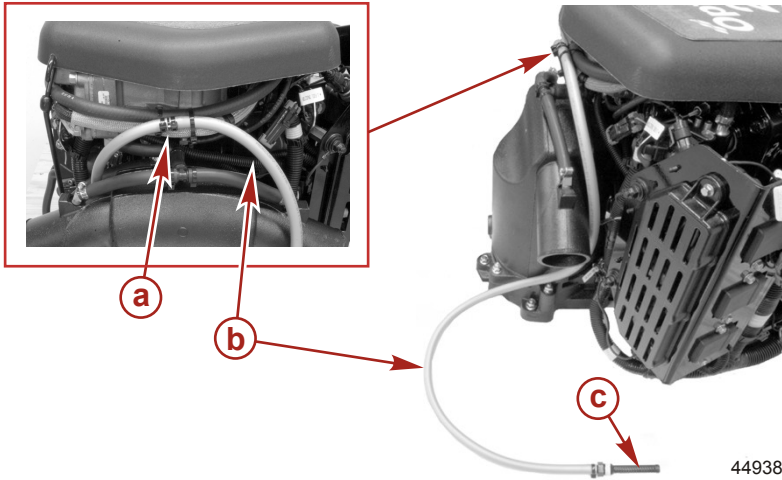

- a** - Siphon break
- b** - Bilge hose
- c** - Bilge water pickup screen

1. Inspect the pickup screen for foreign material. Clean if necessary.
2. Inspect the hole in the siphon break for blockage. Clean with a small wire if necessary.
3. Ensure that the siphon break is secured above the waterline.

Submerged Power Package

A submerged power package requires prompt service by an authorized dealer after recovery. This immediate attention is necessary once the engine is exposed to the atmosphere to minimize internal corrosion damage to the engine.

STORAGE

Storage Preparation

The major consideration in preparing your Mercury Jet Drive for storage is to protect it from rust, corrosion, and damage caused by freezing of trapped water.

The following storage procedures should be followed to prepare your Mercury Jet Drive for out of season storage or prolonged storage (two months or longer).

NOTICE

Without sufficient cooling water, the engine, the water pump, and other components will overheat and suffer damage. Provide a sufficient supply of water to the water inlets during operation.

FUEL SYSTEM

IMPORTANT: Gasoline containing alcohol (ethanol or methanol) can cause a formation of acid during storage and can damage the fuel system. If the gasoline being used contains alcohol, it is advisable to drain as much of the remaining gasoline as possible from the fuel tank, remote fuel line, and engine fuel system.

The most effective method for storage preparation is to add the recommended amount of Mercury Precision Fuel Stabilizer and Mercury Precision Quickleen products as described on their containers to the fuel tank before the last operation of the boat. Adding fuel stabilizer will help prevent the formation of varnish and gum in the gasoline. The Mercury Precision Quickleen product will help clean and lubricate the fuel injectors.

1. Portable fuel tank - Pour the required amount of gasoline stabilizer (follow instructions on container) into fuel tank. Tip fuel tank back and forth to mix stabilizer with the fuel.
2. Permanently installed fuel tank - Pour the required amount of gasoline stabilizer (follow instructions on container) into a separate container and mix with approximately one quart (one liter) of gasoline. Pour this mixture into the fuel tank.
3. Remove the water separating fuel filter from the engine. Empty the fuel into a suitable container and discard the filter properly.

STORAGE

4. Premix the following in a container:
 - 8 cc (0.27 oz) or two teaspoons of Mercury Precision Quickleen lubricant.
 - 8 cc (0.27 oz) or two teaspoons of Mercury Precision Fuel Stabilizer.
5. Pour this mixture in a new water separating fuel filter. Install the fuel filter.
6. Fill the fuel system as follows:
 - a. Turn the ignition key switch to the "ON" position for three seconds and then back to the "OFF" position for five seconds.
 - b. Continue this procedure five times to allow the electric fuel pump to fill the fuel system.
7. Using the flushing adapter, start the engine and allow the engine to run at idle speeds for 10 minutes to allow the treated fuel to fill the fuel system.

Protecting Internal Engine Components

*NOTE: Make sure the fuel system has been prepared for storage. Refer to **Fuel System**, preceding.*

IMPORTANT: Refer to Spark Plug Inspection and Replacement for correct procedure for removing spark plug leads.

1. Remove the spark plugs and add approximately 30 ml (1 oz) of engine oil into each spark plug hole.
2. Rotate the flywheel manually several times to distribute the oil in the cylinders.
3. Install spark plugs.

TROUBLESHOOTING

Starter Motor Will Not Crank the Engine

POSSIBLE CAUSES

- Blown 20 amp fuse in the starting circuit. Refer to **Maintenance**.
- Mercury Jet Drive is not shifted to neutral position.
- Weak battery or battery connections are loose or corroded.
- Ignition key switch failure.
- Wiring or electrical connection faulty.
- Starter motor solenoid or slave solenoid failure.

Engine Will Not Start

POSSIBLE CAUSES

- Lanyard stop switch not in "RUN" position.
- Battery not fully charged.
- Incorrect starting procedure. Refer to **Operation** section.
- Old or contaminated fuel.
- Fuel is not reaching the engine.
 - Fuel tank is empty.
 - Fuel tank vent not open or restricted.
 - Fuel line is disconnected or kinked.
 - Fuel filter is obstructed. Refer to **Maintenance** section.
 - Fuel pump failure.
 - Fuel tank filter obstructed.
- Open 20 amp fuse. Check fuses, refer to **Maintenance** section.
- Threaded connection of an air hose is loose.
- Ignition system component failure.
- Spark plugs fouled or defective. Refer to **Maintenance** section.

TROUBLESHOOTING

Engine Runs Erratically

POSSIBLE CAUSES

- Spark plugs fouled or defective. Refer to **Maintenance** section.
- Incorrect setup and adjustments.
- Fuel is being restricted to the engine.
 - a. Engine fuel filter is obstructed. Refer to **Maintenance** section.
 - b. Fuel tank filter obstructed.
 - c. Stuck antisiphon valve on built-in fuel tank.
 - d. Fuel line is kinked or pinched.
 - e. Injector plugged.
- Threaded connection of an air hose is loose.
- Fuel pump failure.
- Ignition system component failure.

Performance Loss at Normal RPM

POSSIBLE CAUSES

- Boat overloaded or load improperly distributed.
- Excessive water in bilge.
- Boat bottom is dirty or damaged.

Performance Loss at Wide-Open Throttle

LOW RPM (USUALLY ENGINE RELATED)

- Throttle not fully open.
- Exhaust system blocked.
- Ignition system problem.
- Fouled spark plug or failed injector.
- Air compressor inlet blockage.

HIGH RPM (USUALLY PUMP RELATED)

- Damaged impeller.
- Worn impeller or worn wear ring.

TROUBLESHOOTING

- Fouled impeller, inlet, or stator.
- Ride plate seal leak.

Battery Will Not Hold Charge

POSSIBLE CAUSES

- Battery connections are loose or corroded.
- Low electrolyte level in battery.
- Worn out or inefficient battery.
- Excessive use of electrical accessories.
- Defective rectifier, alternator, or voltage regulator.

OWNER SERVICE ASSISTANCE

Local Repair Service

Always return your Mercury Jet Drive to your local authorized dealer should the need for service arise. Only he has the factory trained mechanics, knowledge, special tools, equipment, and genuine parts and accessories to properly service your engine should the need occur. He knows your engine best.

Parts and Accessories Inquiries

All inquiries concerning genuine replacement parts and accessories should be directed to your local authorized dealer. The dealer has the necessary information to order parts and accessories for you. When inquiring about parts and accessories, the dealer requires the model and serial number to order the correct parts.

Service Assistance

Your satisfaction with your Mercury Jet Drive product is very important to your dealer and to us. If you ever have a problem, question, or concern about your Mercury Jet Drive product, contact your dealer or any authorized Mercury Marine dealership. If additional assistance is required, take these steps:

1. Talk with the dealership's sales manager or service manager. If this has already been done, then contact the owner of the dealership.
2. Should you have a question, concern, or problem that cannot be resolved by your dealership, please contact a Mercury Marine Service Office for assistance. Mercury Marine will work with you and your dealership to resolve all problems.

The following information will be needed by the service office:

- Your name and address
- Daytime telephone number
- Model and serial number of your outboard
- The name and address of your dealership
- Nature of problem

OWNER SERVICE ASSISTANCE

Mercury Marine Service Offices

For assistance, call, fax, or write. Please include your daytime telephone number with mail and fax correspondence.

United States, Canada		
Telephone	English - (920) 929-5040 Français - (905) 636-4751	Mercury Marine W6250 W. Pioneer Road P.O. Box 1939 Fond du Lac, WI 54936-1939
Fax	English - (920) 929-5893 Français - (905) 636-1704	
Website	www.mercurymarine.com	

Australia, Pacific		
Telephone	(61) (3) 9791-5822	Brunswick Asia Pacific Group 41-71 Bessemer Drive Dandenong South, Victoria 3175 Australia
Fax	(61) (3) 9706-7228	

Europe, Middle East, Africa		
Telephone	(32) (87) 32 • 32 • 11	Brunswick Marine Europe Parc Industriel de Petit-Rechain B-4800 Verviers, Belgium
Fax	(32) (87) 31 • 19 • 65	

Mexico, Central America, South America, Caribbean		
Telephone	(954) 744-3500	Mercury Marine 11650 Interchange Circle North Miramar, FL 33025 U.S.A.
Fax	(954) 744-3535	

Japan		
Telephone	072-233-8888	Kisaka Co., Ltd. 4-130 Kannabecho Sakai-shi Sakai-ku 5900984 Osaka, Japan
Fax	072-233-8833	

Asia, Singapore		
Telephone	(65) 65466160	Brunswick Asia Pacific Group T/A Mercury Marine Singapore Pte Ltd 29 Loyang Drive Singapore, 508944
Fax	(65) 65467789	

OWNER SERVICE ASSISTANCE

Ordering Literature

Before ordering literature, please have the following information about your power package available:

Engine Model:		Horsepower:	
Serial Number:		Model year:	

UNITED STATES AND CANADA

For information on additional literature that is available for your particular Mercury/MerCruiser power package and how to order that literature contact your nearest dealer or contact:

MERCURY MARINE		
Telephone	Fax	Mail
(920) 929-5110	(920) 929-4894	Mercury Marine Attn: Publications Department P.O. Box 1939 Fond du Lac, WI 54936-1939

OUTSIDE THE UNITED STATES AND CANADA

Contact your nearest dealer or Marine Power Service Center for information on additional literature that is available for your particular Mercury/MerCruiser power package and how to order that literature.

MAINTENANCE LOG

Maintenance Log

Record all maintenance performed on your Mercury Jet Drive here. Be sure to save all work orders and receipts.

Date	Maintenance Performed	Engine Hours